

1 ELECTRICAL

Two amplifier models are available. One model has a 50/60 Hz power transformer with two 120 V ac primary windings. These windings may be wired in parallel or series for operation at either 120 V ac or 220/240 V ac. The other amplifier model is for export into countries where the ac line voltage is 100 volts, 50/60 Hz. The next two sections refer to the first model with the dual 120 V ac primary windings.

1.1 120 V ac, 50/60 Hz Power Connections

The amplifier is provided with the primary of the power transformer strapped for 120 V ac operation from the factory. Refer to Figure 2a for the wiring details.

WARNING: Verify that the power transformer's primary circuit configuration is correct for the intended ac line voltage *BEFORE* applying power to the amplifier.

1.2 220/240 V ac, 50/60 Hz Power Connections

The power transformer has two 120 volt primary windings which can be connected in parallel for 120 V ac line voltages, or in series to meet 220/240 V ac requirements. Use the following procedures to re-strap the primary of the power transformer for 220/240 V ac applications.

1. Make sure the amplifier is not connected to any power source.
2. Remove and save the eleven screws securing the top cover. There are three screws on each side and three along the top-rear edge of the chassis. In addition, you must remove the two innermost screws inset into the top bumper strip. Refer to Figure 1 for the exact screw locations.

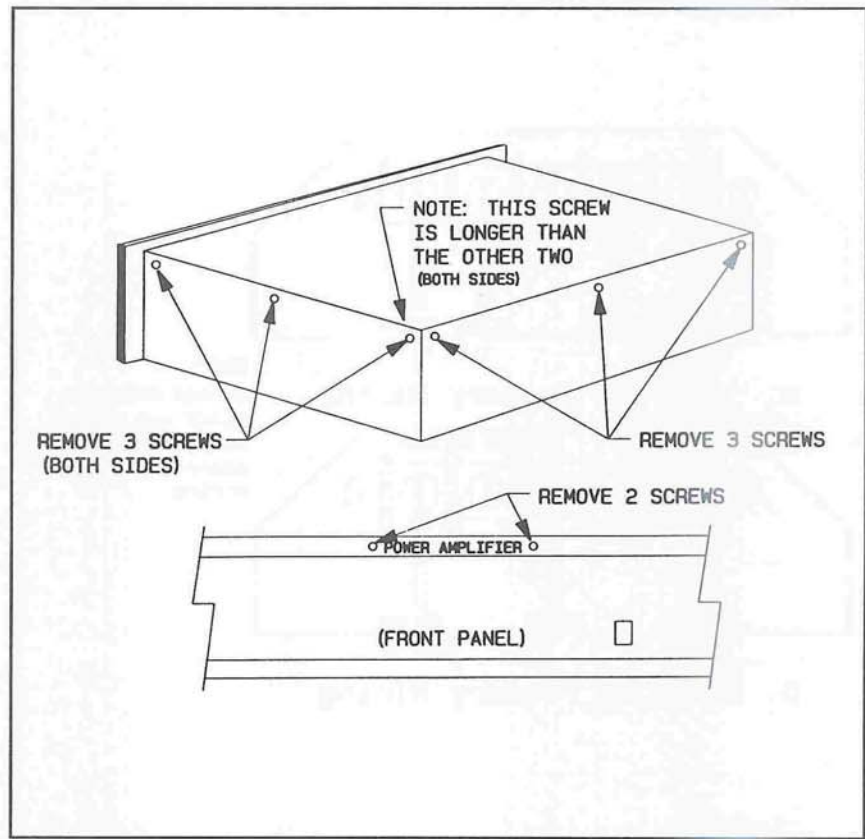

Figure 1 Top Cover Removal

3. Locate the barrier strip mounted on the top-rear edge of the power transformer. Referring to Figure 2b, reconnect the leads as shown.
4. Install the top cover with the eleven screws previously removed. Two screws are longer than the others removed from the sides and rear. These longer screws install into the rearmost position on each side of the chassis.
5. Install an 8 amp fuse, Littelfuse Type 3AB 8A/250V slo-blo® 326-series ceramic body or equivalent.

2 INSTALLATION

2.1 Rack Mounting

The amplifier may be installed in a standard 19 inch equipment rack. It requires 5¼ inches of vertical rack space and secures to the rack cabinet with the four rack mount screws and cup washers provided in the hardware kit.

2.2 Ventilation

The amplifier must be adequately ventilated to avoid excessive temperature rise. It should not be used in areas where the ambient temperature exceeds 60 °C (140 °F). To determine the ambient air temperature, operate the system in the rack until the temperature stabilizes. Measure the ambient air with a bulb-type thermometer held at the bottom of the uppermost amplifier. Do not let the thermometer touch the metal chassis because the chassis will be

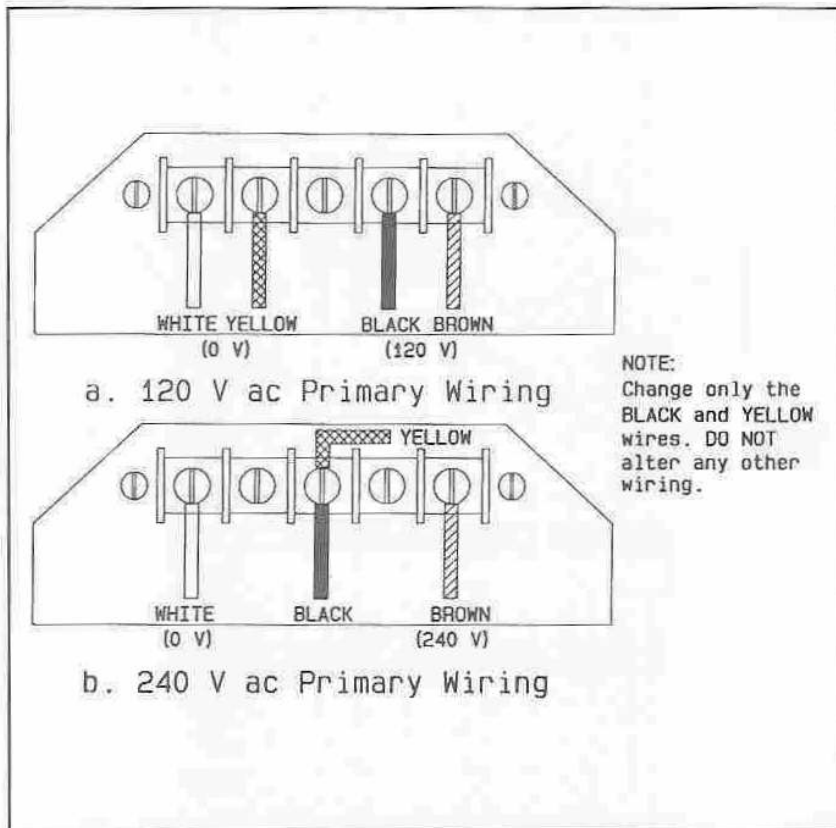

Figure 2 Primary Wiring Configuration for 120 V ac and 220/240 V ac

hotter than the ambient air. If the air temperature exceeds 60 °C (140 °F), the equipment should be spaced at least 1.75 inches apart or a blower installed to provide sufficient air movement within the cabinet.

WARNING: Do not operate the amplifier within a completely closed unventilated housing.

3 SIGNAL CONNECTIONS

3.1 Input Connections

Balanced input connections may be made to either the barrier strip or the female XLR connectors. For single-ended inputs, strap the low (—) input to ground (pin 3 on XLR). Otherwise, the electronically-balanced input stage will see 6 dB less input signal level than with a bal-

anced input. Refer to Figure 3 for typical input connections.

3.2 Line Output Connections

The XLR and barrier strip connectors are wired in parallel. Pin 2 of the XLR is the (+) input on the barrier strip, and pin 3 is the (—) input. Since the input impedance of the electronically-balanced input stage is high (15 K ohms), there is minimal loading on the signal source. When the input connections are made to one connector, the other may be used as an auxiliary line output to feed other high input impedance equipment. Refer to Figure 3 for possible applications.

3.3 Output Connections

Output connections are made to the four terminal barrier strip connector. Refer to Figure 4

for typical output connections.

3.4 Output Cable Selection

Speaker wire size plays an important part in quality sound systems. Small wire gauges can waste power and reduce the damping factor at the speaker terminals. This can add coloration and muddiness to the sound. To help offset this problem, Table I has been assembled to enable you to calculate the power losses in the speaker cable.

3.4.1 Calculating Power Losses with 8 ohm Loads

To calculate the total power loss in the speaker cable, multiply the power loss per foot (or meter) of the 2-wire cable selected from Table I by the length of the cable in feet (or meters). For example, suppose an installer uses 160 feet of 10 GA 2-wire cable with an 8 Ω speaker system. The total power loss in the cable is:

Total Power Loss in cable

$$= 0.1013 \text{ watts/foot} \times 160 \text{ feet}$$

$$= 16.2 \text{ watts}$$

Does this mean that whenever the amplifier produces 400 watts of output power, 383.8 watts (400 watts minus 16.2 watts) will be delivered to the 8 ohm load? NO! The actual load impedance is 8 ohms plus the resistance of the cable (0.00204 ohms/foot times 160 feet) for a total load impedance of 8.3264 ohms. At the 8 Ω rated output power, the output voltage is 56.57 V rms. Therefore, the amplifier produces 384.3 watts with this load instead of 400 watts. This was calculated by squaring the voltage and dividing by the load impedance (56.57² divided by 8.3264 ohms). As a result, the actual power delivered to the load is 368.1 watts (384.3 watts minus 16.2 watts).

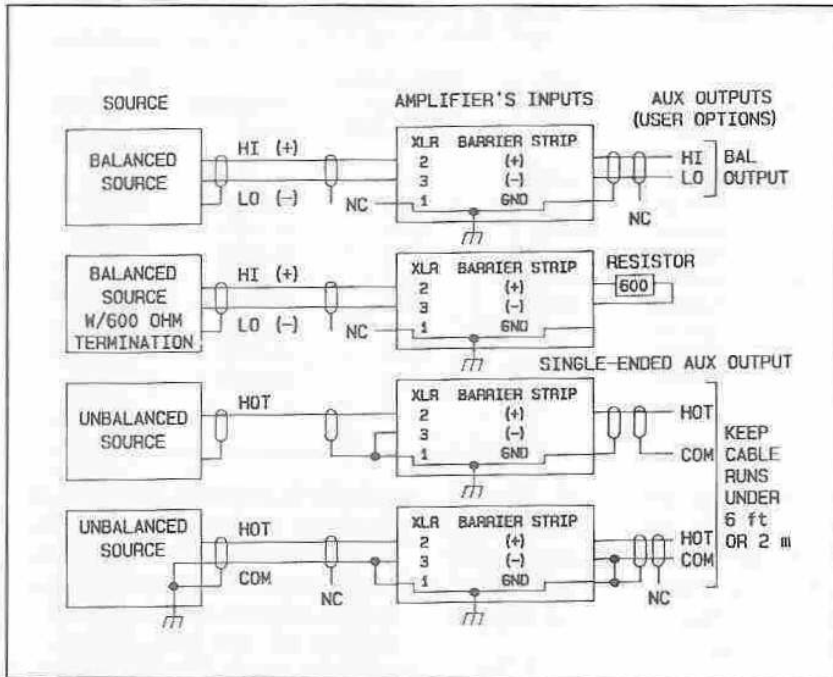

Figure 3 Typical Input Connections

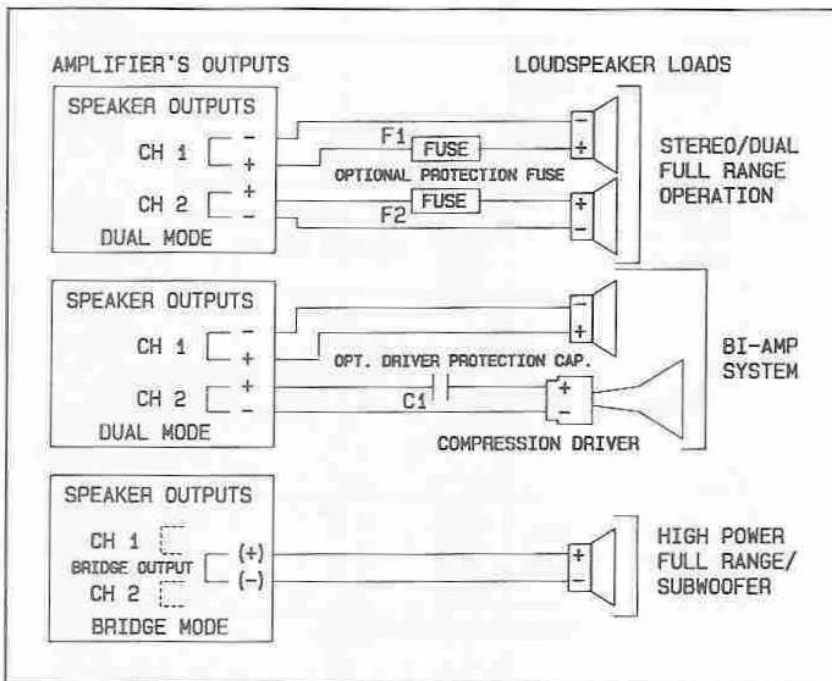

Figure 4 Typical Output Connections

Had 18 GA wire been used in the above example, the loss in the cable would have been 100.8 watts. This example illustrates the

importance of using the proper wire size.

3.4.2 Calculating Power

Losses with 4 ohm Loads

To calculate the losses when using a 4 ohm speaker system, multiply the loss at 8 ohms by 3. In the above example, the 10 GA wire would consume 48.6 watts of power while the 18 GA wire would waste 302.5 watts - more than half of the amplifier's 4 ohm power rating.

3.5 Damping Factor

The higher the damping factor rating of an amplifier, the greater the ability of the amplifier to control unwanted speaker cone movements. When a signal drives a woofer, current flowing through the voice coil creates a magnetic field. This field interacts with the permanent magnetic field in the gap and forces the combination cone and voice coil assembly to move outward. When the signal is removed, the assembly moves inward but its momentum causes it to overshoot its resting point. This overshoot will dampen itself out eventually but the unwanted movements can add considerable distortion products to the sound.

In the process of moving inward through the magnetic field, the voice coil assembly generates a current of opposite polarity to the original signal. This current induces a voltage or "back EMF" which travels through the speaker wire to the amplifier's output. The lower the amplifier's output impedance, the faster the overshoot of the voice coil will dampen out. The output impedance of an amplifier can be calculated by dividing the rated output impedance, typically 8 ohms, by the damping factor. The 9446A has a damping factor rating of 250 which corresponds to an output impedance of 0.032 ohms.

3.5.1 Calculating the Maximum Length of Cable for a Specified Damp-

ing Factor Specification at the Load

The damping factor rating is typically never realized at the load because of the resistance of the cable (and other factors such as the contact resistance of an output relay or the resistance of an output fuse). The damping factor at the load should be 30 for general paging systems and 50 for high fidelity music systems. Economics usually dictate, however, that these numbers are cut-in-half. The resulting damping factor at the load should be based on experience and customer satisfaction. Once a minimum damping factor is determined for a particular type of installation, the following equation can calculate the maximum length of 2-wire cable which can be used to achieve the minimum damping factor specified at the load:

Max. Length of 2-wire cable in feet

$$= \frac{ZL}{DF} - Z_0$$

DCR/ft

where

- ZL is the load impedance to connect to the amplifier;
- Z₀ is the amplifier's output impedance (0.032 ohms for the 9446A);
- DF is the minimum permissible damping factor at the load; and
- DCR/ft is the DC resistance of the 2-wire cable per foot from Table I.

The same equation can be used to calculate the maximum cable length in meters by substituting the DCR per meter value from Table I.

Let's use the equation. Suppose ZL equals 8 ohms, Z₀ = 0.032 ohms, and the minimum damping

Table I 9446A Power Losses in 2-wire Speaker Cable

AWG (GA)	DCR/ft (Ω/ft)	Power Loss/ft (watts/ft)	Cable Cross-Sectional area (mm ²)	DCR/meter (Ω/m)	Power Loss/meter (watts/m)
6	0.00081	0.0402	13.30	0.00264	0.1314
8	0.00121	0.0603	8.36	0.00421	0.2082
10	0.00204	0.1013	5.26	0.00669	0.3288
12	0.00324	0.1606	3.31	0.01063	0.5175
14	0.00515	0.2542	2.08	0.01691	0.8108
16	0.00819	0.4011	1.31	0.02685	1.2567
18	0.01302	0.6303	0.82	0.04289	1.9319
20	0.02070	0.9834	0.52	0.06764	2.8752
22	0.03292	1.5185	0.33	0.10658	4.1497

factor at the load is 25. In addition, 18 GA cable is preferred. Then, the maximum length of 18 GA cable which can be used to achieve a damping factor of 25 at the load is:

$$\frac{8}{25} - (0.032) = 22.1 \text{ feet}$$

0.01302 Ω/ft

ge cable is required. However, this may not be practical or economical. The size of the 2-wire cable can be greatly reduced by stepping up the output voltage of the amplifier to 70, 100, 140, or 210 volt, using an output transformer, then stepping down the voltage at the load. Such a system is shown in

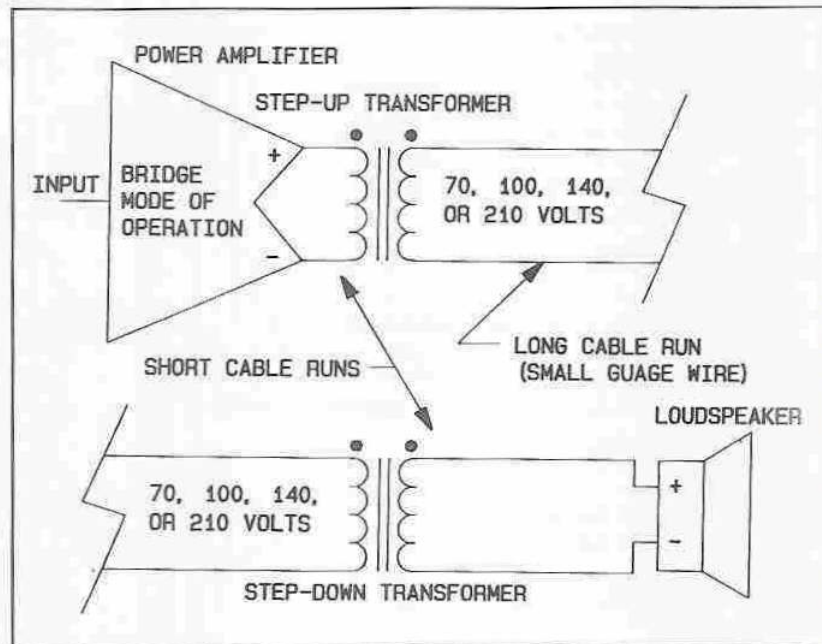

Figure 5 High-voltage Distribution System

Sometimes it may be necessary to locate the speaker 100 feet or more away from the amplifier. In this situation, a much larger gau-

Figure 5.

The maximum length of 2-wire cable in this situation can be ap-

proximated from the following equation:

Max. Length of 2-wire cable in feet

$$\frac{V^2}{(P_{out})(DCR/ft)} \left(\frac{1}{DF} - \frac{Z_o}{Z_L} \right)$$

where

V is the stepped-up voltage of the system;
 P_{out} is the rated output power of the amplifier;
 Z_o is the output impedance of the amplifier (0.032 ohms for the 9446A);
 Z_L is the load impedance;
 DCR/ft is the DC resistance of the 2-wire cable per foot from Table I; and
 DF is the minimum permissible damping factor at the load.

Suppose a 210 volt system were used at a 1200 watt power level to drive an 8 ohm load with a minimum damping factor of 25. Using the same 18 GA cable as before, the maximum length can now be 102 feet. Power companies use this technique to transfer large amounts of power over great distances.

3.6 Speaker Protection Fuse Selection

Sometimes it may be desirable to use in-line fuses (fuses in series with the output) to protect loudspeaker systems (or the amplifier). It is difficult, however, to determine the proper fuse value with the correct time lag and overload characteristics to match the limitations of a speaker system. The values shown in Table II should serve only as a guide. To use, determine the power rating and load value. Then, select a standard value fuse of the next smaller value to the one listed in the table.

The values are calculated for fast-blow fuses which carry 135% of their current rating for an hour but will blow within 1 second at 200%. Other fuse values may be calculated for different power levels from the following equation:

Fuse value =

$$\frac{(P_{out} \times Z_L)^{1/2}}{Z_L \times 1.35} \text{ amps}$$

where

P_{out} is the output power rating of the amplifier; and
 Z_L is the load impedance.

Use 32 volt fuses if possible; they typically have the lowest internal resistance which will help minimize deterioration of the damping factor at the load. Refer to the example in Figure 4.

Table II Calculated Output Fuse Values

Power (watts)	4 Ω Load	8 Ω Load	16 Ω Load
100	3.70	2.62	1.85
150	4.54	3.21	2.27
200	5.24	3.70	2.62
300	6.42	4.54	3.21
400	7.41	5.24	3.70
600	9.07	6.42	4.54

3.7 Compression Driver Protection Capacitors

Compression drivers, used for mid to high frequency sound reproduction, are much more susceptible to damage from low frequencies than large cone loudspeakers. Even though an electronic crossover may be employed, problems may arise in the cables between the crossover and the power amplifier, or from misadjustment of the crossover. Either of these situations could apply low frequency signals or hum to the driver and cause damage. To prevent a potential mishap, ALTEC

LANSING recommends using a capacitor between the amplifier and the compression driver to suppress low frequencies and possible DC. Refer to the example in Figure 4.

In choosing a value, one must be careful not to interfere with the crossover frequency. As a general rule, select a capacitor whose break frequency, with respect to the load, is 3 dB down at approximately 1/2 of the high pass corner frequency.

Mylar capacitors with at least a 100 volt ac rating are recommended. Table III shows the recommended capacitor values for use with 8 and 16 ohm drivers at popular crossover frequencies.

Table III Compression Driver Protection Capacitors

Crossover Frequency	8 Ω Driver	16 Ω Driver
500 Hz	80 μF	40 μF
800 Hz	50 μF	25 μF
1000 Hz	40 μF	20 μF
1250 Hz	33 μF	16 μF
2000 Hz	20 μF	10 μF
3150 Hz	12 μF	6 μF
6300 Hz	6 μF	3 μF

4 OCTAL ACCESSORY SOCKETS

Two octal sockets permit a variety of plug-in accessories to be used with the amplifier. Normally, one "U" jumper is inserted between octal socket pins 8 and 1, and another between pins 7 and 6. *These jumpers must remain in place for the amplifier to operate when not using any accessory modules.* To use with an accessory module, remove (and save) the jumpers and install the module making sure the key on its center post aligns with the groove in the female socket. For operation, refer to the instructions provided with the module. Schematically, the

module will be inserted between the input connector and the balanced input stage.

Electronic modules are powered from a bipolar 15 volt supply in the amplifier. The supply is capable of supplying up to 25 ma DC of current. Currents in excess of 25 ma DC may prevent the amplifier from disengaging from its built-in protection mechanisms.

5 PROTECTION SYSTEMS

5.1 Load Protection Circuitry

Each channel independently protects its load from startup/shutdown transients, DC, and large subsonic signals.

5.2 Amplifier Protection Circuitry

A unique current-limiting circuit was designed specifically for the amplifier. It features a variable current limit which is a function of the output signal voltage. As a result, the amplifier can deliver the rated currents into rated loads but substantially limits the current into low impedance or shorted loads (shorted output terminals). Once the short is removed, however, the amplifier will resume normal operation.

A dual speed fan is also incorporated to provide efficient cooling under the most demanding conditions. When the heatsink temperature at the fin tips reaches approximately 88 °C (190 °F), the fan automatically switches to high speed operation. As the temperature cools to approximately 78 °C (172°F), low speed operation is once again resumed.

The heatsink is also thermally equalized to prevent the output devices nearest the fan from operating at a cooler temperature than the devices at the opposite end.

This minimizes the thermal gradient across the heatsink and forces the devices to operate at more nearly the same temperature. This equalizes the lifetimes and reliability characteristics of the output devices so that no one device becomes the weak link in the chain.

Should the heatsink temperature of a channel remain excessively high, the affected channel will shut down automatically. When the output devices cool to a safe operating temperature, the channel will automatically resume normal operation.

5.3 Protect Indicator

The "PROTECT" LED does not turn-on abruptly as others may do; its intensity is allowed to vary. As a result, its degree of brightness serves as a relative indicator of the severity of the current operating conditions e.g., the brighter the LED, the greater the stress on the channel(s). This provides a visual notification well in advance of any impending shutdown.

Although the channel may still operate with the LED apparently at full brightness, a total shutdown will occur within a few seconds unless the operating conditions improve. If a shutdown does occur, the channel will resume normal operation as soon as its devices have cooled to an acceptable temperature.

6 OPERATION

6.1 Dual Mode of Operation

In the dual mode of operation, the channels may be operated independently. After installation and hookup, verify that the mode switch, located on the rear panel, is in the "DUAL" position and rotate the level controls fully counterclockwise (full attenuat-

ion). Input a 0 dBu (0.775 V rms) nominal signal level and apply power. Slowly increase the level controls until the desired output power is obtained. If either "CLIP" LED illuminates, reduce the output with the channel level control or reduce the input signal level at its source.

WARNING: *Never attempt to connect the outputs of the two channels in parallel.*

6.2 Bridge Mode of Operation

After installation and hookup, verify that the mode switch, located on the rear panel, is in the "BRIDGE" position. Rotate both levels controls fully counterclockwise (full attenuation). Input a 0 dBu (0.775 V rms) nominal signal level into channel 1 only and apply power. Slowly increase the level control of channel 1 until the desired output power is obtained. If either "CLIP" LED illuminates, reduce the output level with the level control or reduce the input signal level at its source.

CAUTION: *Be sure that no input connections are made to channel 2 and that its level control is fully counterclockwise (OFF).*

WARNING: *The bridged output mode provides a true balanced-to-ground output. Do not use any test equipment to test or evaluate this amplifier which does not have floating grounds.*

7 In Case of Problems

Please check the following items:

1. Verify that the amplifier is properly connected to an ac power source and that the source is active.
2. Verify that the input connections are properly