

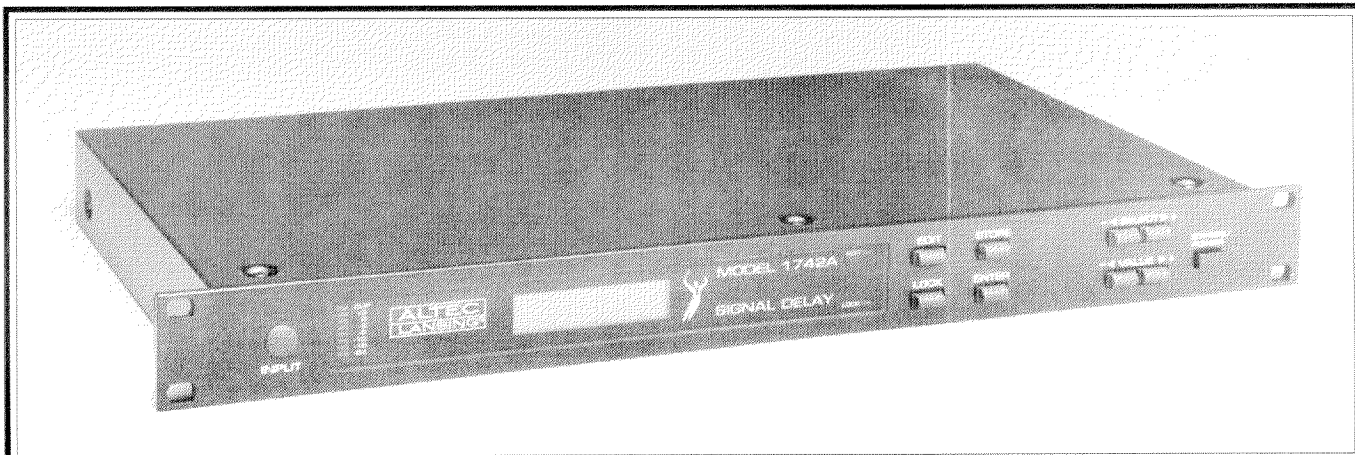

1742A Audio Signal Delay



- ★ Single Input/Two Delayed Outputs
- ★ 16 Bit AD/DA Conversion
- ★ Balanced Input and Outputs
- ★ Control Functions Lock-out

KEY SPECIFICATIONS

Frequency Response:	20 Hz to 20 kHz, +0.5/-2 dB (Ref. 1 kHz, 0 dBm output, 500 kHz measurement bandwidth)
%(THD+Noise):	< 0.02%, 20 Hz to 1 kHz < 0.12%, 1 kHz to 20 kHz 0 dBm output power.
Signal to Noise Ratio:	>86 dB nominal.
Dynamic Headroom:	106 dB
Input Impedance:	
Balanced:	10,000 ohms
Unbalanced:	10,000 ohms
Output Impedance:	150 ohms
Nominal Input Level:	0 dBu
Maximum Input Level:	+21 dBu
Nominal Output Power:	0 dBm
Maximum Output Power:	+21 dBm
Input Topology:	Electronically-balanced
Output Topology:	Electronically-balanced

DESCRIPTION

The ALTEC LANSING model **1742A** Signal Delay is a single input/two output delay unit. Its primary use is for time synchronization of multiple loudspeakers in both cluster type and distributed sound systems. It is suitable for use in any professional or industrial application.

The **1742A** features two independent signal delay sections with individual output level controls. The delay can be measured and set in milliseconds, microseconds (for cluster alignment), feet, inches, meters, and centimeters. Up to 1086 milliseconds of delay is available for each output.

The lockout function of the **1742A** protects against unauthorized operation of the unit. Other features include an adjustable input level with VU, shelving EQ with a gain of ± 14 dB, automatic ac dropout bypass, output muting to suppress turn on/off transients, balanced input and outputs, XLR and barrier strip input and output connectors.

The universal switching power supply accepts voltages from 90 to 260 Vac, 50/60 Hz, without user intervention. Two optional plug-in isolation transformers, the model **15550A** input transformer, and the model **15560A** output transformer are available. The **1742-TMP** is an optional plug-in, positive going temperature probe.

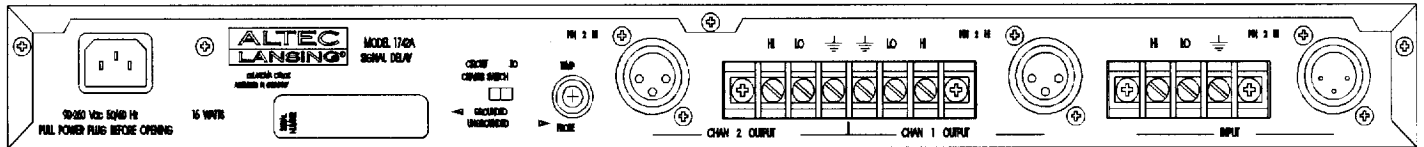

1742A Rear Panel Layout

SPECIFICATIONS (continued)

Measurement Conditions

1. 0 dBu = 0.775 Vrms
2. 0 dBm = 1 mW = 0.775 Vrms across 600 load.
3. Measurements are referred to a 1 kHz, 0 dBu sinewave input signal unless noted.
4. Measurement bandwidth is restricted to 30 kHz unless noted.
5. No isolation transformers installed.

Equalization (shelving type):

EQ-Low:	±14 dB at 100 Hz
EQ-High:	±14 dB at 10 kHz

Polarity:

A positive going signal applied to pin 2 of the XLR-F or the '+' terminal of the input barrier strip produces a positive going signal at pin 2 of the XLR-M and the '+' terminal of the output barrier strip.

Data Format:

16 Bit Linear, Internal 24 Bit

Display:

2 line × 16 character backlit LCD

Propagation Delay:

0.14 mS
(Ref. delay time at 0 mS)

Connectors:

Input:	3-terminal barrier strip, XLR female
Output:	6-terminal barrier strip, Two (2) XLR male.

Power Requirements:

90-260 Vac 50/60 Hz, 15W
Automatically selected by unit
without user intervention

Ground Lift:

Lifts signal common from chassis

Enclosure:

EIA standard rack-mount chassis, 0.22" aluminum front panel.

Dimensions:

Height:	1.75 inches (4.44 cm)
Width:	19.0 inches (48.26 cm)
Depth:	8.13 inches (20.65 cm)

Weight:

8.0 lbs.

Included Accessories:

Rack-mount Hardware Kit,
IEC power Cord,
Operating Instructions

Optional Accessories:

15550A plug-in input
isolation transformer
15560A plug-in output
isolation transformer
1742-TMP plug-in positive
going temperature probe

Altec Lansing continually strives to improve products and performance. Therefore specifications are subject to change without notice.

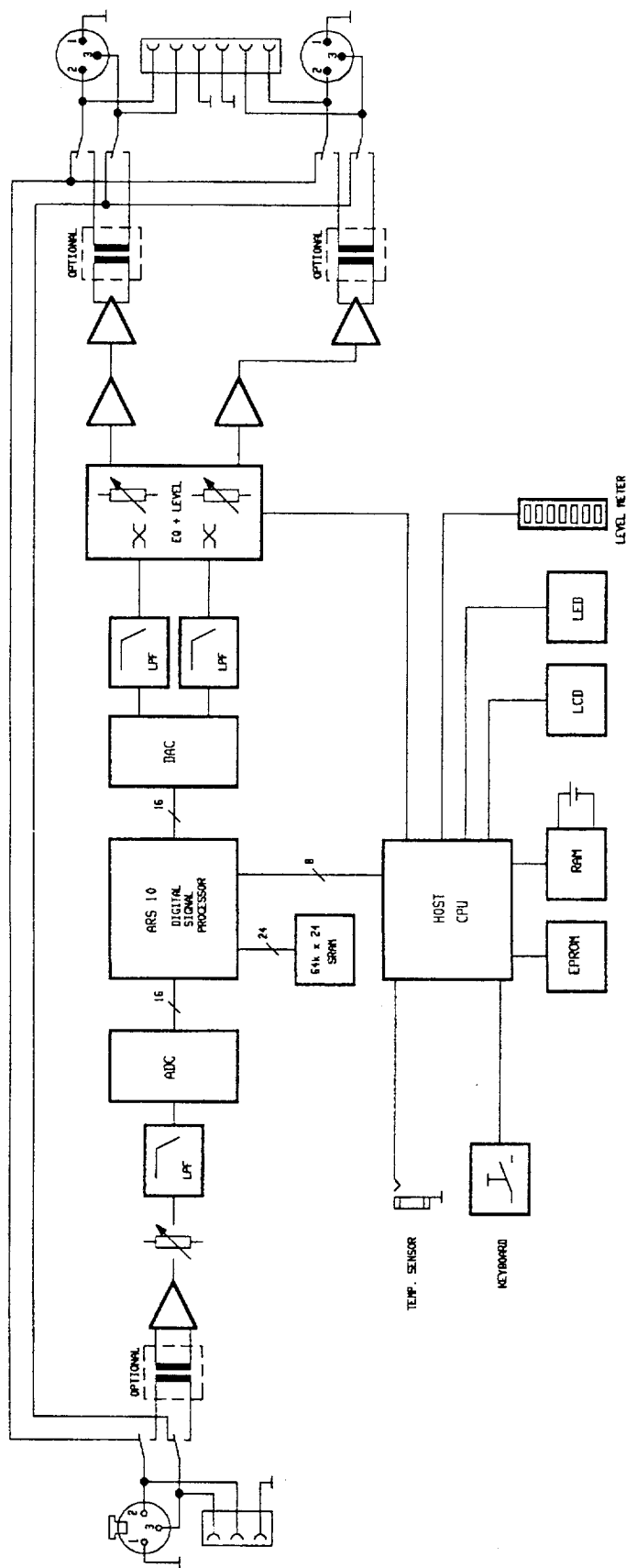

Block Diagram of the 1742A

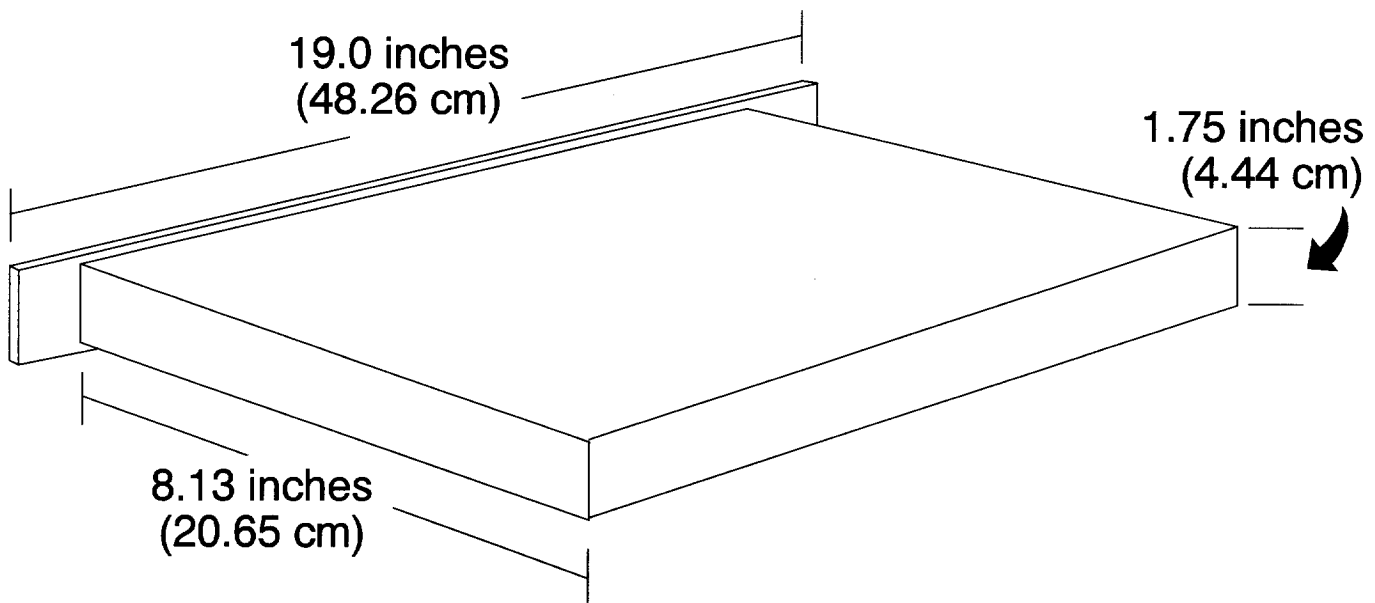

1742A Dimensions

ARCHITECT'S and ENGINEER'S SPECIFICATIONS

The signal delay shall have two independent signal delay sections and individual output level controls. Furthermore, the unit shall have control functions lockout, automatic AC dropout bypass, and output muting.

The front panel shall have the following attributes: a variable input control with VU; a 2 x 16 character LCD readout; edit, lock, store, enter, select, value, and bypass/power switches.

The rear panel shall have input and output connectors, a temperature probe input, a ground lift switch, and an IEC connector.

The input connectors shall be balanced and consist of a 3-terminal barrier strip and female XLR connector. The output connectors shall be balanced and consist of a 6-terminal barrier strip and male XLR connector.

The signal delay shall meet or exceed the following specifications: frequency response, 20 Hz - 20 kHz, +0.5/-2 dB; signal to noise ratio greater than 86 dB; dynamic headroom of 106 dB; balanced input impedance of 10 k Ω ; a maximum output level of +21 dBm into loads greater than or equal to 600 Ω .

The signal delay shall operate on voltages between 90 and 260 VAC, 50/60 Hz, which will be selected by the universal switching power supply. The chassis shall be steel with a black front panel and top, bottom, sides, and back with white nomenclature. The chassis shall have the following dimensions: Height: 1.75 inches; Width: 19.0 inches; Depth: 8.13 inches. The weight shall be 8.0 lbs.

The signal delay shall be the Altec Lansing model 1742A.



a MARK IV company

P.O. BOX 26105 • OKLAHOMA CITY, OK 73126-0105 • U.S.A.

Phone: 405/324-5311 or FAX: 405/324-8981

© 1993 ALTEC LANSING CORPORATION



the sound of experience.

1742A Signal Delay

Installation and Operating Instructions



ALTEC LANSING CORPORATION

a MARK IV company

P.O. Box 26105 • Oklahoma City, OK • 73126-0105 USA • Tel: (405) 324-5311 • FAX: (405) 324-8981

Table of Contents

1	ELECTRICAL	1
2	INSTALLATION	1
2.1	Rack Mounting	1
2.2	Ventilation	1
3	SIGNAL CONNECTIONS	1
3.1	Input Signal Connections	1
3.1.1	Connecting Balanced Lines	1
3.1.2	Connecting Unbalanced Lines	1
3.2	Output Signal Connections	1
3.2.1	Connecting Balanced Lines	1
3.2.2	Connecting Unbalanced Lines	1
4	OPERATION	2
4.1	Front Panel Controls and Functions	2
1.	EDIT Button	2
2.	STORE Button	2
3.	LOCK Button	2
4.	ENTER Button	2
5.	-< SELECT >+ Buttons	3
6.	-< VALUE >+ Buttons	3
7.	OPTION Mode	3
8.	Input Level Control	3
9.	Bypass/Power Switch	3
5	INSTALLING OPTIONAL INPUT AND OUTPUT LINE TRANSFORMERS	4
6	SPECIFICATIONS	5
7	FACTORY SERVICE	7
7.1	In Case of Problems	7
7.2	Factory Service	7
7.3	Technical Assistance	7

1 ELECTRICAL

The 1742A utilizes an universal switching power supply that accepts voltages from 90 to 260 Vac 50/60 Hz without user intervention.

2 INSTALLATION

2.1 Rack Mounting

The Signal Delay may be installed in a standard 19 inch (48.3 cm) equipment rack. It requires one rack unit (1.75 inches or 4.45 cm) of vertical rack space and secures to the rack cabinet with the four screws and cupwashers provided in the hardware kit.

2.2 Ventilation

The Signal Delay must be adequately ventilated to avoid an excessive temperature rise. It should not be used in environments where the ambient temperature exceeds 60 °C (140 °F). To determine the ambient air temperature, operate the equipment in the rack until the temperature stabilizes. Measure the ambient air with a bulb-type thermometer or the Altec Lansing 1742-TMP held at the bottom of the uppermost unit (amp, EQ, attenuator, etc.). Do not let the thermometer touch the metal chassis because the chassis may be hotter than the ambient air. If the air temperature exceeds 60 °C, the equipment should be spaced at least one rack unit apart, or a blower installed to provide sufficient air movement within the cabinet.

3 SIGNAL CONNECTIONS

3.1 Input Signal Connections

3.1.1 Connecting Balanced Lines

Connect the non-inverting (+) side of the line to the "HI" input terminal or pin 2 of the XLR-F connector and the inverting (-) side to the "LO" input terminal or pin 3 of the XLR-F connector. In keeping with standard wiring practices, the shield should not be connected at this end; it should be connected only to the GND or pin 1 of the XLR-M connector of the sending end (Refer to Figure 1).

3.1.2 Connecting Unbalanced Lines

Connect the "hot" wire to the "HI" input terminal or pin 2 of the XLR-F and the returning shield wire to the "GND" input terminal or pin 1 of the XLR-F connector. To avoid a 6 dB drop in level, strap the "LO" input terminal to the "GND" terminal or strap pins 1 and 3 of the XLR-F connector (Refer to Figure 1). If a hum should occur, remove the strap.

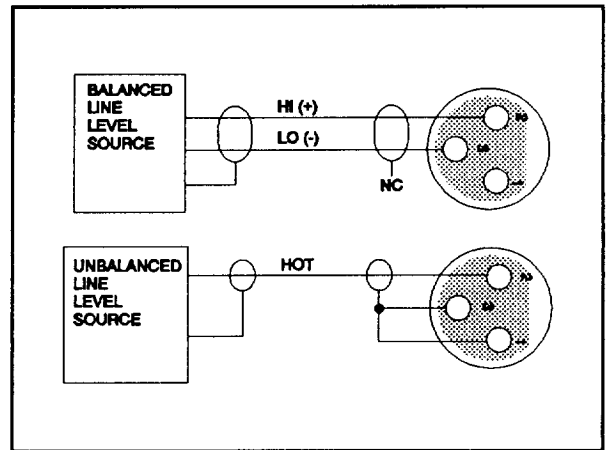

Figure 1 Input Connections

3.2 Output Signal Connections

3.2.1 Connecting Balanced Lines

Connect the non-inverting (+) side of the line to the "HI" output terminal or pin 2 of the XLR-M connector and the inverting (-) side to the "LO" output terminal or pin 3 of the XLR-M connector. In keeping with standard wiring practices, the shield should be connected to the "GND" or pin 1 XLR-M connector of the this end; it should not be connected at the receiving end (Refer to Figure 2).

3.2.2 Connecting Unbalanced Lines

Connect the "hot" wire to the "HI" output terminal or pin 2 of the XLR-M connector and the shield wire to the "GND" output terminal or pin 1 of the XLR-M connector. To avoid a 6 dB drop in level, strap the "LO" input terminal to the "GND" terminal or strap pins 1 and 3 of the XLR-F connector (Refer to Figure 2). If a hum should occur, remove the strap.

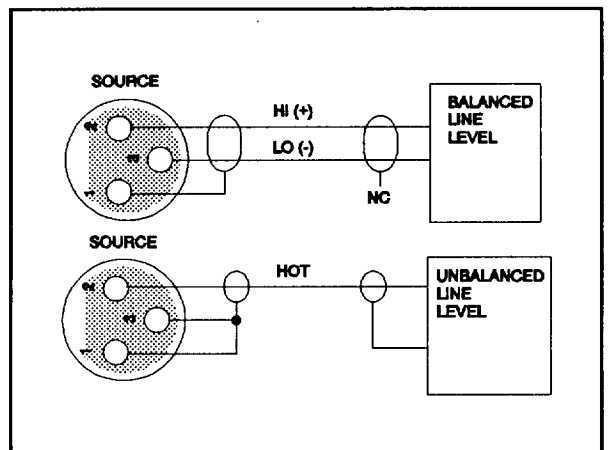
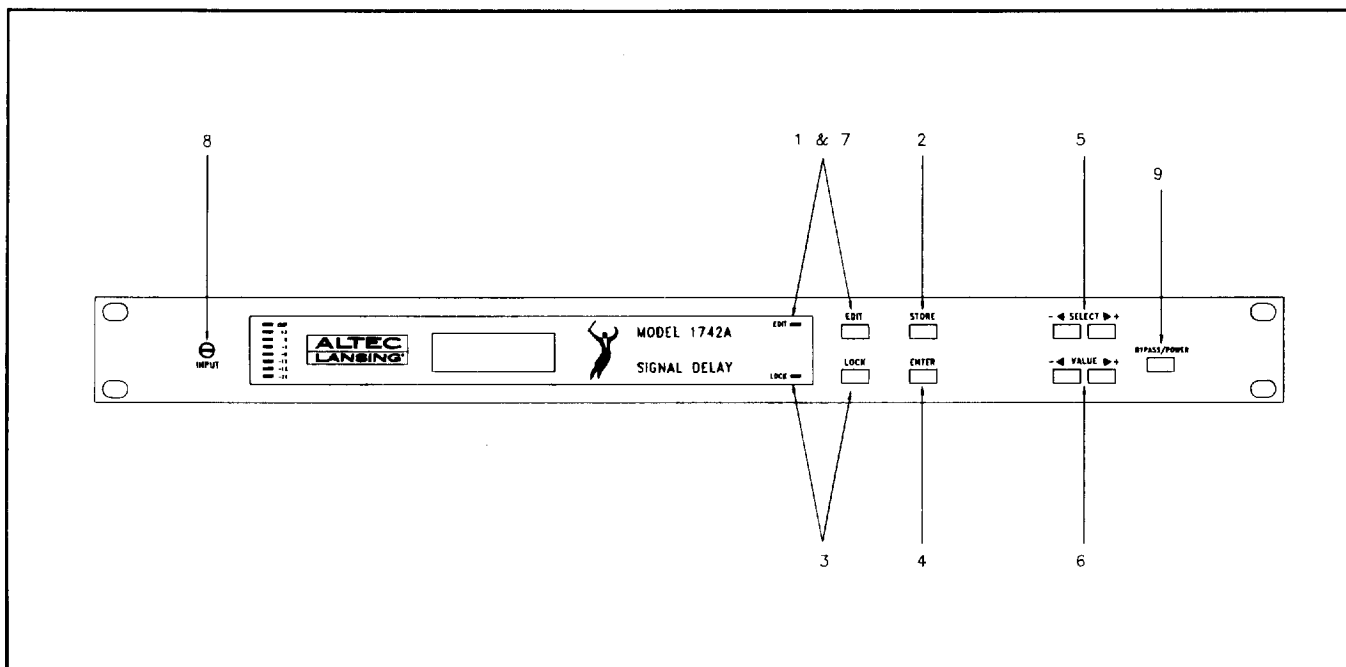

Figure 2 Output Connections



Pictorial 1 Front Panel Controls

4 OPERATION

4.1 Front Panel Controls and Functions (Refer to Pictorial 1)

1. EDIT Button

This Button changes the operation to EDIT mode and OPTION mode. After pressing this button, the first parameter of the active program is shown. Further parameters are accessible via the SELECT buttons. The value of the parameters shown can be changed via the VALUE buttons. By pressing the EDIT button again, the OPTION mode is accessed where unique settings for the unit can be made or checked.

For further information please see the OPTION mode section.

2. STORE Button

With this button, programs can be stored in memory locations (01 - 30).

To store programs:

- press STORE
- select new program number with
-< VALUE >+ buttons then press
ENTER
- confirm with STORE
- cancel with any other key

3. LOCK Button

This button allows the user to lock/unlock the keyboard of the 1742A.

To lock the unit:

- press LOCK, the LOCK LED is blinking
- select code number with -< VALUE >+ buttons
- press ENTER
- Confirm by pressing LOCK, the LOCK LED is fully illuminated
- or cancel with any other key

To unlock the unit:

- press LOCK, the LOCK LED is blinking
- select correct code number with the
-< VALUE >+ buttons
- press ENTER to unlock, the LOCK LED is off

For unlocking without code number (lock override):

- press LOCK and ENTER simultaneously during power on

4. ENTER Button

With this button, new programs are activated after selection and storage of programs or locking of the unit. In addition, the button is used to leave the EDIT mode without storing.

5. -< SELECT >+ Buttons

In PLAY mode these buttons select the previous or next program number (activated by pushing ENTER). In EDIT mode it is used for selecting parameters. In OPTION mode the option functions are selected.

6. -< VALUE >+ Buttons.

With these buttons, parameter values can be altered in EDIT mode and OPTION mode. For storage the new program number is selected, and locking the code number is selected with these buttons. Parameters are edited here. The EDIT mode is activated by the EDIT key and indicated via the EDIT LED.

The following parameters can be edited within the given range:

- CONFIGURATION:

- Single Delay
- Delay 1 Delay 2
- Cluster Align

- EQ LOW: -14dB - +14dB
- EQ HIGH: -14dB - +14dB

- DELAY 1 LEVEL: OFF, -63dB - +16dB
- DELAY 2 LEVEL: OFF, -63dB - +16dB

- DELAY 1 TIME:
 - 00 ms - 1086 ms
 - 00 ft. - 1223 ft.
 - 02 in. - 14676 in.
 - 00 m - 373 m
 - 05 cm - 37303 cm

- DELAY 2 TIME:
 - 00 ms - 1086 ms
 - 00 ft. - 1223 ft.
 - 02 in. - 14676 in.
 - 00 m - 373 m
 - 05 cm - 37303 cm

- DELAY 2 ALIGNMENT:
 - 5000 μ s - +5000 μ s
 - 67.5 in. - +67.5 in.
 - 1715 mm - +1715 mm

- DELAY TIME UNIT:
 - millisec.
 - feet
 - inch
 - meter
 - centimeter

7. OPTION Mode

In OPTION mode, unique settings for the unit can be made or checked. It is activated by pressing the EDIT key twice.

The following functions are available:

- LCD CONTRAST -10 - +10
- VU DISPLAY MODE
(In reference to the Input)
 - Peak hold
 - NO Peak
 - Slow
- TEMPERATURE UNIT
 - in Celsius
 - in Fahrenheit
- SOFTWARE VERSION
 - e. g. ALTEC 1742A
 - Software V 1.0

8. Input Level Control

This control adjusts the gain of the Input amplifier to accommodate the wide range of signal strengths present by the endless variety of signal sources. Correctly setting the Level Control results in the best Signal-to-Noise ratio, the greatest dynamic range, and freedom from overload distortion.

9. Bypass/Power Switch

Pressing this switch IN applies primary AC power to the unit. Pressing this switch again (out) places the unit into Bypass mode. This allows an unmodified signal to pass from input to output when the unit's power is off.

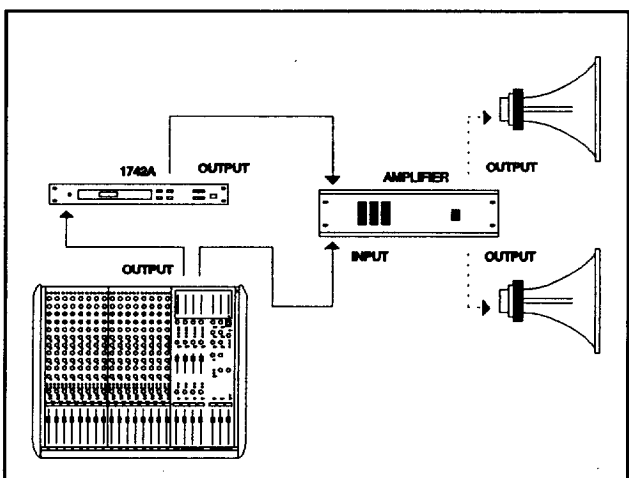

Figure 4 Typical DELAY1 Configuration

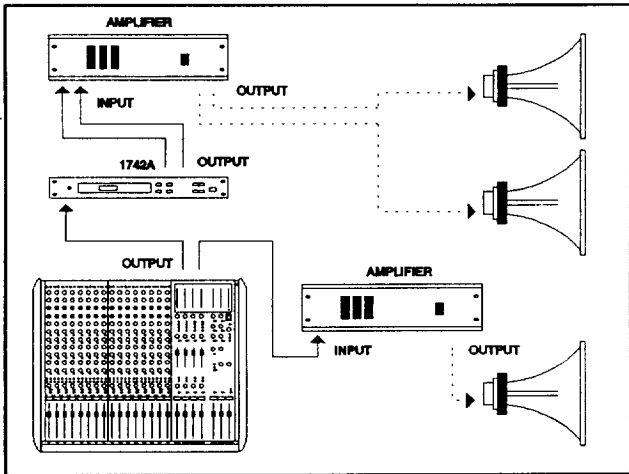

Figure 5 Typical DELAY1 DELAY2 Configuration

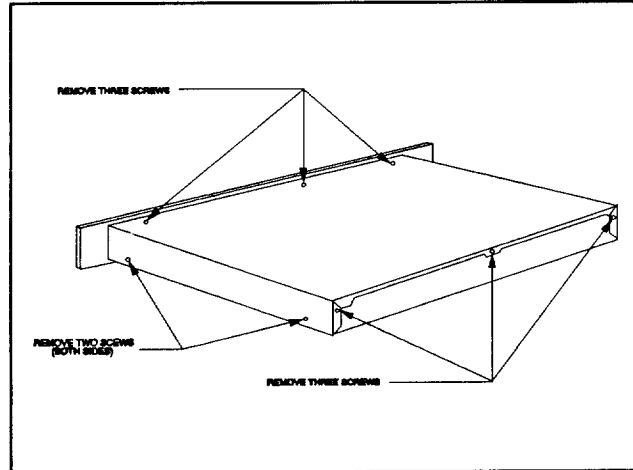

Figure 7 Top Cover Screw Locations

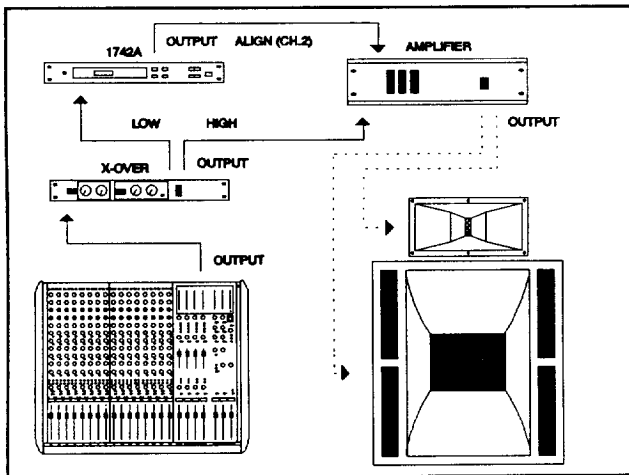

Figure 6 Typical DELAY + ALIGN Configuration

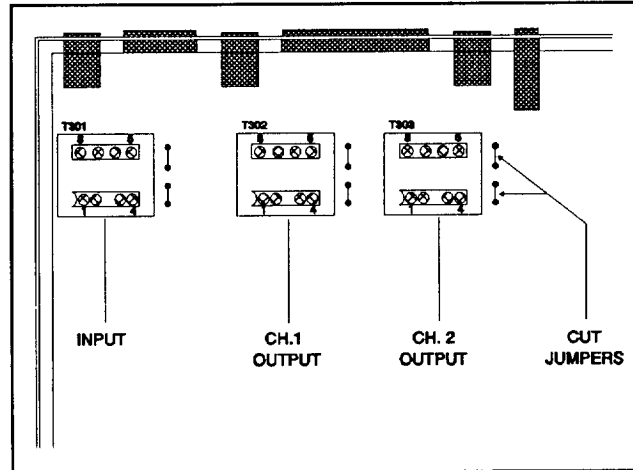

Figure 8 Transformer and Jumper Locations

5 INSTALLING OPTIONAL INPUT AND OUTPUT LINE TRANSFORMERS

The Model 15550A line transformer is available to provide isolation for the input if necessary. The Model 15560A line transformer is also available to provide isolation for the output if desired. Use the following procedures to install the 15550A and the 15560A line transformers.

1. Disconnect the 1742A from the AC power source.
2. Remove the ten screws securing the top cover (see Figure 7).
3. Locate the transformer mounting areas near rear of the unit on top of the P.C.B. (see Figure 8 for exact locations).
4. Cut two jumpers for each transformer installed (see Figure 8 for exact locations).
5. Insert the transformers into the pin receptacles inside its desired mounting area (The orientation of the pin receptacles is keyed so that the transformer can be inserted only one way).
6. Install the top cover with the ten screws previously removed.

6 SPECIFICATIONS

Conditions:

1. 0 dBu = 0.775 Vrms
2. 0 dBm = 1 mW = 0.775 Vrms across 600 Ω load.
3. Measurements are referred to a 1 kHz, 0 dBu sinewave input signal unless noted.
4. Measurement bandwidth is restricted to 30 kHz unless noted.
5. No isolation transformers installed.

Input Topology:

Electronically-balanced

Input Impedance:

Balanced: 10k Ω
Unbalanced: 10k Ω

Nominal Input Level: 0 dBu

Maximum Input Level: +21 dBu

Output Topology: Electronically-balanced

Output Impedance: 150 Ω

Nominal Output Power: 0 dBm

Maximum Output Power: +21 dBm

Frequency Response:

20 Hz to 20 kHz, + 0.5 / - 2 dB
(Ref. 1 kHz, 0 dBm output, 500 kHz measurement bandwidth)

%(THD+Noise): < 0.02%, 20 Hz to 1 kHz
< 0.12%, 1 kHz to 20 kHz
at 0 dBm output power

Nominal Signal to Noise Ratio: >86 dB

Dynamic Headroom: 106 dB

Equalization (shelving type):

EQ-Low: ± 14 dB at 100 Hz
EQ-High: ± 14 dB at 10 kHz

Polarity:

A positive going signal applied to pin 2 of the XLR-F or the '+' terminal of the input barrier strip produces a positive going signal at pin 2 of the XLR-M and the '+' terminal of the output barrier strip.

Propagation Delay: (Ref. Delay time at 0 ms)
0.14 ms

Data Format: 16 Bit Linear, Internal 24 Bit

Display: 2 line \times 16 character backlit LCD

Connectors:

Input: 3 terminal barrier strip, XLR-F

Output: 6 terminal barrier strip, 2 XLR-Ms

Power Requirements:

90 - 260 Vac, 50/60 Hz, 15W
Automatically selected by 1742A
without user intervention.

Ground Lift: Lifts signal common from chassis

Enclosure: 1 EIA standard rack-mount chassis,
0.22" aluminum front panel

Dimensions:

Height: 1.75 inches (4.44 cm)
Width: 19.0 inches (48.26 cm)

Included Accessories:

Rack-mount Hardware Kit, IEC
power Cord, Operating Instructions

Optional Accessories:

15550A plug-in input isolation
transformer
15560A plug-in output isolation
transformer
1742-TMP plug-in positive going
temperature probe.

Altec Lansing continually strives to improve products and performance. Therefore specifications are subject to change without notice.



1742A

Signal Delay

SERVICE INSTRUCTIONS

*****CAUTION*****

No user serviceable parts inside. Hazardous voltage and currents may be encountered within the chassis. The service information contained within this document is for use only by ALTEC LANSING'S authorized warranty stations and qualified service personnel. To avoid electric shock, DO NOT perform any servicing other than that contained in the Operating Instructions unless you are qualified to do so. Refer all servicing to qualified service personnel.

7 SERVICE INFORMATION

CAUTION: *No user serviceable parts inside. Hazardous voltages and currents may be encountered within the chassis. The service information contained within this document is for use only by ALTEC LANSING authorized warranty stations and qualified service personnel. To avoid electric shock DO NOT perform any servicing other than that contained in the Operating Instructions unless you are qualified to do so. Otherwise, refer all servicing to qualified service personnel.*

NOTE: *Modifications to ALTEC LANSING products are not recommended. Such modifications shall be at the sole expense of the person(s) or company responsible, and any damage resulting therefrom shall not be covered under warranty or otherwise.*

7.1 In Case of Problems

Please check the following items:

1. Verify that the unit is properly connected to an ac power source and that the source is active.
2. Verify that the input connections are properly made. Refer to Figure 1.
3. Verify that the output connections are properly made. Refer to Figure 2.
4. Check the input and output cables for proper wiring and continuity.
5. Check the signal source.
6. If the following message appears after switching the unit on:

"Service Required Chng. Int. Battery"

please refer to Section 7.2 for factory service information.

WARNING: *User programs may be lost when the battery is low.*

7.2 Factory Service

If factory service is required, ship the unit prepaid to:

ALTEC LANSING Customer Service/Repair
10500 W. Reno
Oklahoma City, OK 73128 U.S.A.

Enclose a note describing the problem in as much detail as possible. Include other helpful information such as test conditions, where used, how used, etc.

7.3 Technical Assistance

For applications assistance/technical information, write or call:

ALTEC LANSING Technical Assistance
P.O. Box 26105
Oklahoma City, OK 73126-0105
U.S.A.
Phone: (405) 324-5311
FAX: (405) 324-8981

ADDENDUM

TO THE ALTEC LANSING 1742A SIGNAL DELAY INSTALLATION AND OPERATING INSTRUCTIONS

The following is a change to the INSTALLING OPTIONAL INPUT AND OUTPUT TRANSFORMERS section of the Altec Lansing 1742A Signal Delay INSTALLATION AND OPERATING INSTRUCTIONS (Part Number 42-02-038253).

5 INSTALLING OPTIONAL INPUT AND OUTPUT LINE TRANSFORMERS

The Model 15550A line transformer is available to provide isolation for the input if necessary. The Model 15560A line transformer is also available to provide isolation for the output if necessary. Use the following procedures to install the 15550A and the 15560A line transformers.

1. Disconnect the 1742A from the AC power source.
2. Remove the ten screws securing the top cover (see Figure 7).
3. Locate the transformer mounting areas near rear of the unit on top of the P.C.B. (see Figure 8 for exact locations).
4. Cut two jumpers for each transformer installed (see Figure 8 for exact locations).
5. Insert resistor R316 (6.8 k Ω , Part # 47-01-102098) and capacitor C316 (820 pF, Part # 15-06-037792) at its reserved locations (see Figure 8 for exact locations).
6. The output electrolytic capacitors C366, C368, C322 and C324 are to be shorted by a tin link on the solder pad provided on the P.C.B. (see Figure 8 for exact locations).
7. Insert the transformers into the pin receptacles inside its desired mounting area (The orientation of the pin receptacles is keyed so that the transformer can be inserted only one way).
8. Install the top cover with the ten screws previously removed.

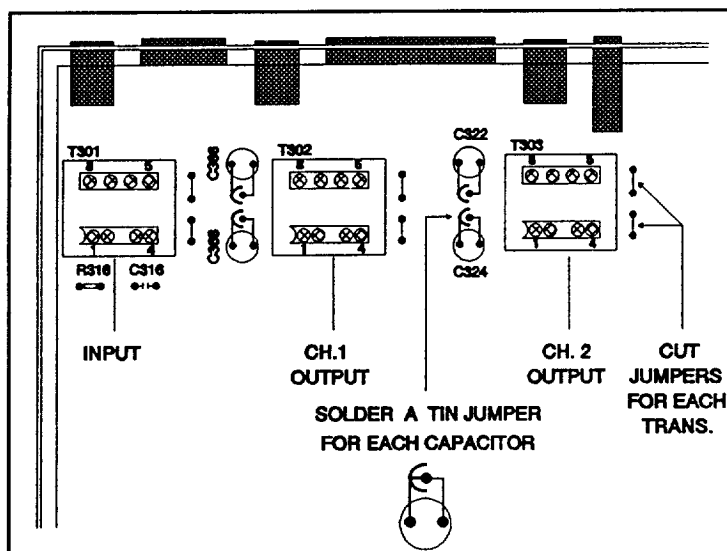

Figure 8 Transformer and Jumper Locations