

**AUDITORIUMS • STADIUMS • ARENAS • THEATRES • AIRPORT TERMINALS
OUTDOOR VOICE WARNING SYSTEMS • INDUSTRIAL AND COMMERCIAL
INSTALLATIONS**

The exponential multicellular horn is the most efficient of all projectors for delivering top quality sound uniformly over a defined listening area. The unique excellence of the multicellular horn results from its distinctive design:

- (a) The multicellular horn consists of a number of individual horns assembled in various configurations to provide controlled angles of vertical and horizontal distribution for best sound coverage of any listening area.
- (b) Each horn or cell of the multicellular horn is a straight exponential trumpet through which sound can pass unimpeded. This is a distinct advantage over horns of the re-entrant or reflex type which severely attenuate the high frequencies and cause distortion due to sharp folds or bends in the sound passage.
- (c) The column speaker exercises control of sound only in the vertical plane, whereas the multicellular horn controls sound in both the vertical and horizontal planes thus providing the added advantage of restricting sound projection into reverberant side walls.
- (d) The re-entrant or reflex horn and the column speaker are handicapped by the fact that the beam width becomes steadily narrower as frequency increases, to a point where sound coverage in the critical high frequency range between 2,000 and 10,000 cycles shrinks to a narrow pencil of sound, in some cases only 15° to 30° wide.

In contrast, the beam width of the multicellular horn above the cross-over region and in the important mid- and high-frequency regions to 12,000 cycles and be-

yond, is independent of frequency. This entire portion of the frequency spectrum is uniformly distributed throughout the full angle of the horn.

- (e) The multicellular horn with its great undistorted power handling capacity (up to 400 watts) is unequalled by any other commercially available sound over large outdoor areas.

Altec multicellular horns will accommodate as many as four drivers of the 288 type for indoor use, or 730 and 290 type for outdoor use. The latter drivers and the 30546 angle adaptor in combination with a multicell horn constitutes a complete All-Weather system.

The multicellular horn was developed to insure the success of early talking pictures. Ordinary horns proved incapable of providing good quality coverage to every seat in large theatres, most of which were far from ideal acoustically. The folded horn was discarded in theatre work in 1934 and since that time the multicellular horn has remained the standard of excellence.

The 300 cycle cutoff multicellular horn is often used as a "one-way" speaker where voice only is to be reproduced, or where maximum intelligibility is required to penetrate high ambient noise levels, or for projection over long outdoor distances.

The 500 cycle multicellular horn with a 500 cycle crossover network and low frequency speakers, Altec 416A or 515B, are generally used for full range "two-way" loudspeaker systems such as Altec "Voice of the Theatre" systems for the reproduction of high quality voice and music.



A Division of *LS* Ling Altec, Inc.

1515 S. Manchester Ave., Anaheim, Calif. 92803
New York

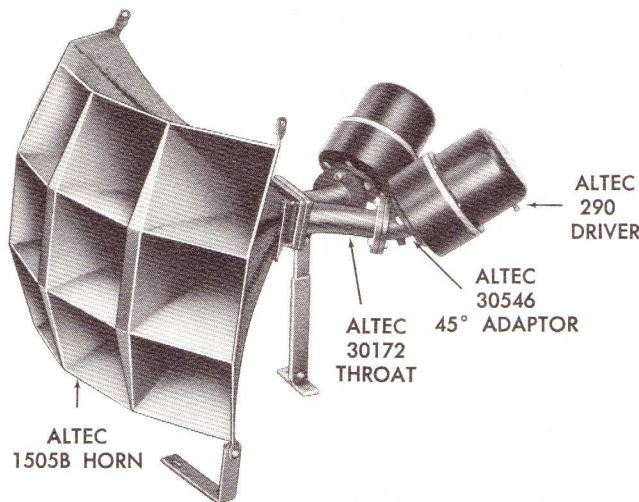
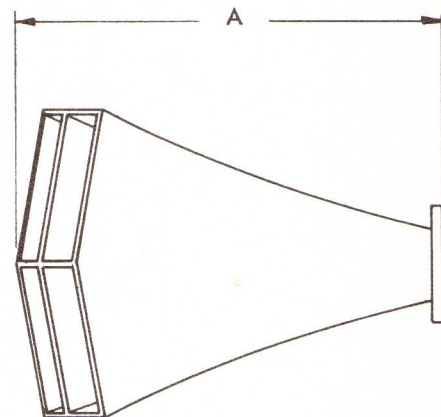
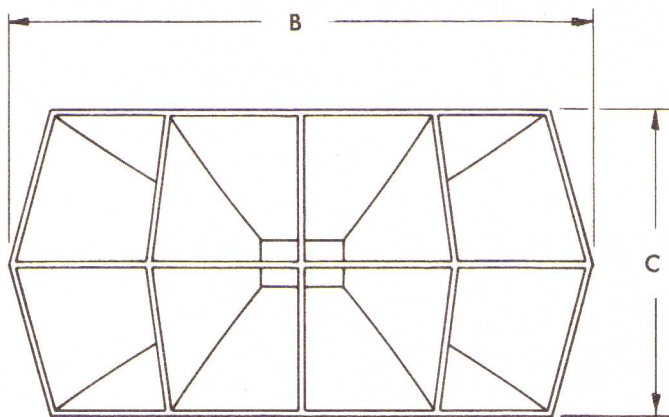

TYPICAL MULTICELLULAR HORN AND DRIVER COMBINATION

21216 adapter

30162 horn throat (single unit)

30166 horn throat (single unit)

30170 horn throat (double unit)

30172 horn throat (double unit)

30210 horn throat (single unit)

30546 45° weatherproof throat adapter

30619 90° throat adapter

30296 doghouse (supplied with models 1004, 1504, and 1804 only)

Multicellular Horns

HOW TO SELECT THE CORRECT MULTICELLULAR HORN FOR SPECIFIC AREA COVERAGE

Multicellular projectors are available in several configurations. The sound distribution pattern (angle) is determined by the cell arrangement. Each cell of a 500 cycle horn projects sound over an area of 20° square, or 400 square degrees per cell; a 400 cycle horn distributes sound over an area of 19° square per cell and a 300 cycle horn over an area of 17½° square per cell (203B horn — 20° square per cell). The sound distribution pattern, both horizontal and vertical, of a horn, is established by the total number of cells assembled in each plane.

Determine the area to be covered and, by reference to the chart on page 4 of this bulletin, select the horn having a distribution pattern which will most closely cover this area. To obtain full advantage of controlled distribution, no greater area of sound coverage should be provided than can be effectively used. Multicellular horns are composed of a group or stack of individual horns so that each small horn becomes a component part of the large horn assembly. All cells are fed from a common throat.

The partial spherical front achieved by grouping the cells allows each cell to contribute to the whole without overlap or confusion. In installations where speech only is to be projected, the projection ability of a 300 cycle horn can be increased by sharply cutting off the low frequency energy fed the horn an octave above the rated cutoff of the horn by use of an Altec N-500C network or the 15045A 70-volt line transformer. In this manner, the horn has an effective length considerably greater than its physical length. By selection of the proper cell configuration, the projected sound is fully controlled in both the vertical and horizontal plane and this feature proves useful in combating high reverberation and in minimizing or eliminating acoustic feedback. A 300 cycle horn in combination with a 500 cycle crossover network, will greatly aid in overcoming objectionable reverberation by giving the horn greater projection ability by restricting the radiation of the low frequencies, which are often undesirable in the masking of sound and contribute little or nothing to speech intelligibility.

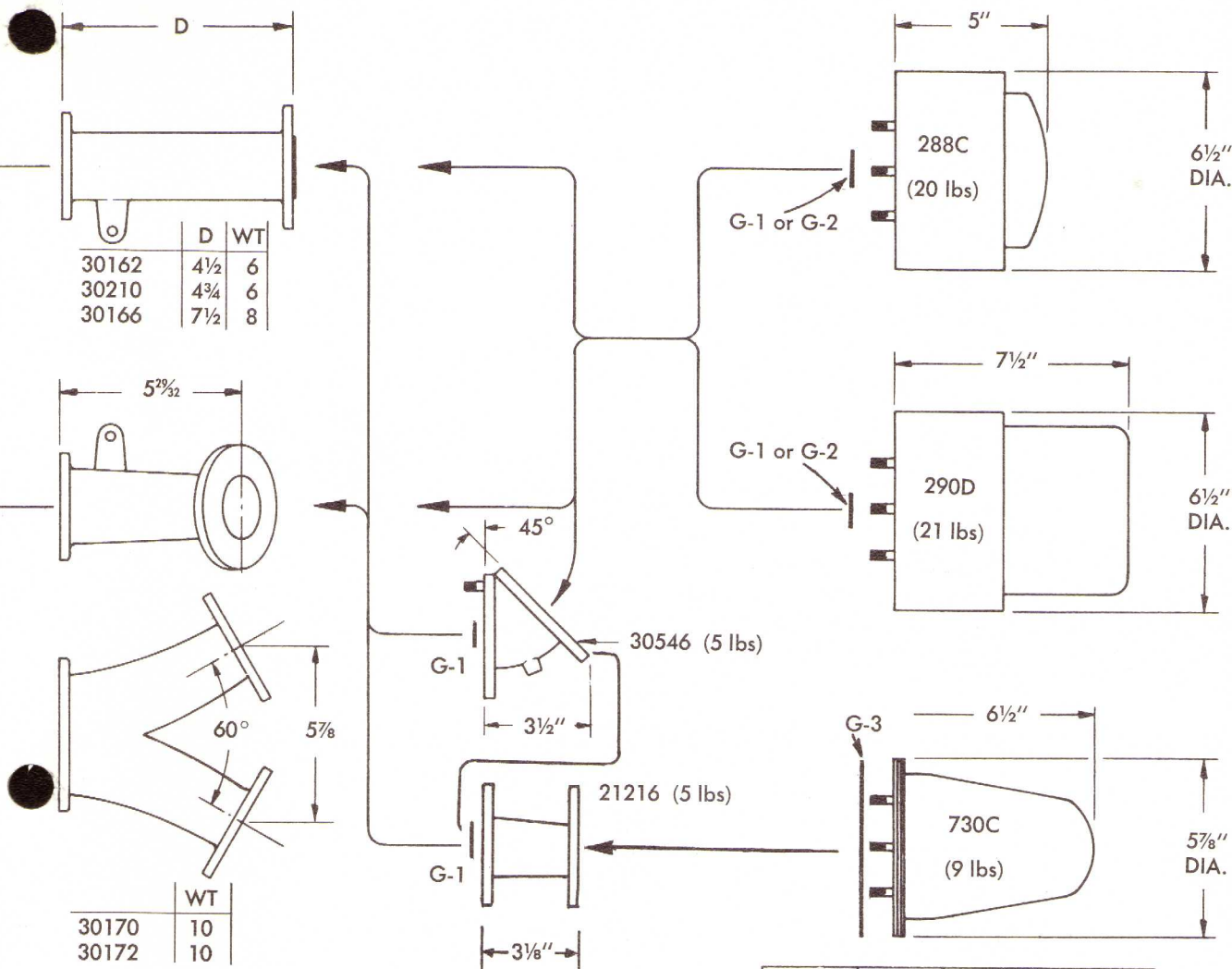

	D	WT
30162	4 1/2	6
30210	4 3/4	6
30166	7 1/2	8

	WT
30170	10
30172	10

GASKET REQUIREMENTS FOR ALL MULTICELLULAR HORNS AND ASSOCIATED PARTS

1. Connection of 288 or 290 Drivers to Adapter, Throat, or Horn.

- When mounting an adapter, throat, or horn with a male fitting to a 288 or 290 Driver, a 20466 (0.02" thick, No. 1) gasket must be inserted between adapter, throat, or horn and the driver.
- When mounting an adapter, throat or horn with a flush face to a 288 or 290 Driver, a 21270 (0.125" thick, No. 3) gasket must be inserted between adapter, throat, or horn and the driver.
- When mounting a 203B Multicellular Horn to a 288 or 290 Driver, no throat is required. Insert a 21270 gasket between the 203B Horn and the driver. If an adapter is desired, rule a or b above apply.

2. Connection of 730C Driver to Adapter. When mounting the 730C Driver to the 21216 Adapter, use a 21263 (0.093" thick, No. 2) gasket between the driver and the adapter.

HORN	A	B	C	WT.
203B	31	32	17	22
803B	26 1/2	32	16 1/4	27
804B	23 1/2	32	16 1/4	25
805B	17 1/2	24 1/2	13	17
1003B	25 1/2	38	16 1/8	32
1004B	*20 1/2	38 1/2	16 1/4	30
1005B	17 1/4	30	13	20
1504B	*21	38 3/4	24	48
1505B	16 3/4	30 1/2	18 1/2	22
1803B	27 1/2	44	24	60
1804B	*23 1/2	44	24	58

*(Add 4" for throat adapter)
(Furnished)

GASKET SPECIFICATIONS

No.	Altec P/N	O.D.	I.D.	Thickness
1+	20466	2"	1.406"	0.02"
2++	21263	4"	1"	0.093"
3+	21270	2"	1.406"	0.125"

- + Supplied with drivers and adapters
- ++ Supplied with 730C Driver

NOTICE

We recommend that you obtain your Altec products from factory trained authorized Altec Sound Contractors and Distributors. This will assure you of proper installation, a continuing source of knowledgeable advice, service, and quick warranty protection.

