

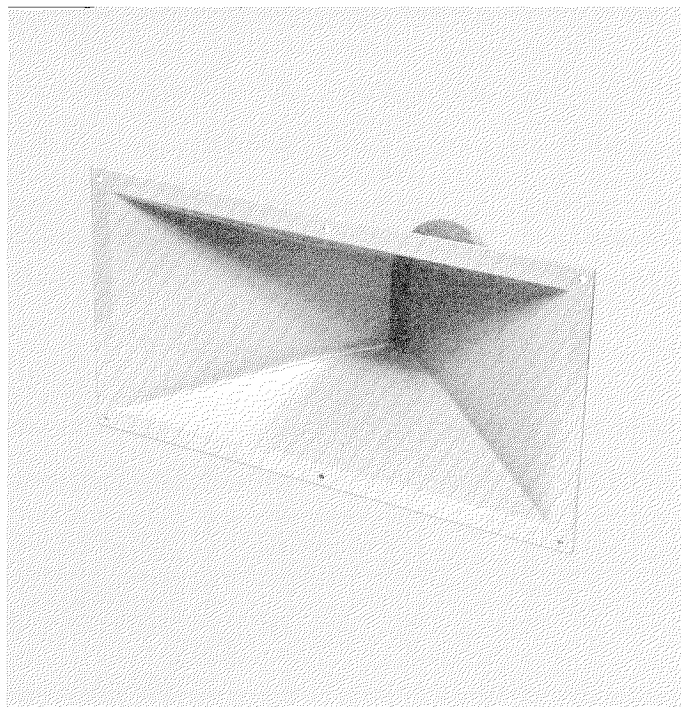

MR II 5124 MANTARAY CONSTANT DIRECTIVITY HORN



DESCRIPTION

The Altec Lansing MR II 5124 is a 120° x 40° mid/high-frequency horn with efficient low-frequency loading down to 500 Hz, having excellent directivity control over the full frequency range to 16 kHz.

The result of a continuing research project by Altec Lansing, the MR II 5124 is a radical departure from previous horn designs. The geometry of the MR II 5124 minimizes the problem of high-frequency beaming and maintains uniform dispersion at all frequencies within the rated frequency bandpass. This greatly benefits the listeners sitting off-axis of a MANTARAY horn, as they will hear the same sound quality as listeners sitting on-axis.

Performance is shown graphically in the MR II 5124's test results. Polar patterns look nearly identical at all frequencies from 2 kHz to 16 kHz. Frequency response curves show similar uniformity both on-axis and off-axis.

The MANTARAY horn is constructed of heavy-duty, weather resistant polyester/fiberglass. This construction technique results in a horn design that is surprisingly light weight, yet extremely rugged and non-resonant. A steel driver/horn mounting bracket is included for ease of mounting.

SPECIFICATIONS

Nominal Dispersion Angle:	120° x 40°	
Dispersion Angle vs. Frequency:	See Figure 1	
Mean Dispersion Angle—	Horizontal	Vertical
(2 kHz to 16 kHz):	111° (+9°, -37°)	39° (+9°, -6°)
Standard Deviation (σ):	14°	5°
Polar Patterns:	See Figure 6	
Solid Angle Coverage (1 to 2 kHz):	See Figure 5	
Frequency Response:	See Figures 2 and 3	
Directivity Index (DI):	See Figure 4	
Directivity Factor (Q or R₀):	See Figure 4	
Mean Directivity (Q) (2 kHz to 16 kHz):	8.6 (+9.3, -2.3) (See Figure 4)	

Useable Low Frequency Limit:	500 Hz
Pressure Sensitivity dB (SPL):	Measured on axis 10 feet from the horn mouth with one watt (E x I) of pink noise band-limited from 500 Hz to 16 kHz and calculated to one meter equivalent by inverse square law.

Driver	Power Level	1 Meter	4 Feet
288	1 watt	109	107
	15 watts	121	119
290	1 watt	107	105
	100 watts	127	125
291	1 watt	108	106
	40 watts	124	122

Dimensions	12.75" (32.4 cm) high 24.3" (61.7 cm) wide 12.5" (31.75 cm) deep
-------------------	--

Weight :	5 lbs. (2.3 kg)
-----------------	-----------------

REFERENCE LITERATURE

"The Mantaray Horns," C. A. Henricksen and M. Ureda, **J. Audio Eng. Soc.**, vol. 26, p 629-634 (1978 Sept.)

"Apparent Apex Theory: Far-Field Polar Characteristics at Close Proximity," M. Ureda, **J. Audio Eng. Soc.** (Abstracts), vol. 26, p 988 (1978 Dec.)

"Coverage of Multiple Mantaray Horns," M. Ureda and T. Uzzle, **Tech. Letter #262**, Altec Lansing.

1. Dispersion Angle vs Frequency

This graph displays the MR II 5124 excellent horizontal and vertical directivity control. Note the uniformity above 2000 Hz.

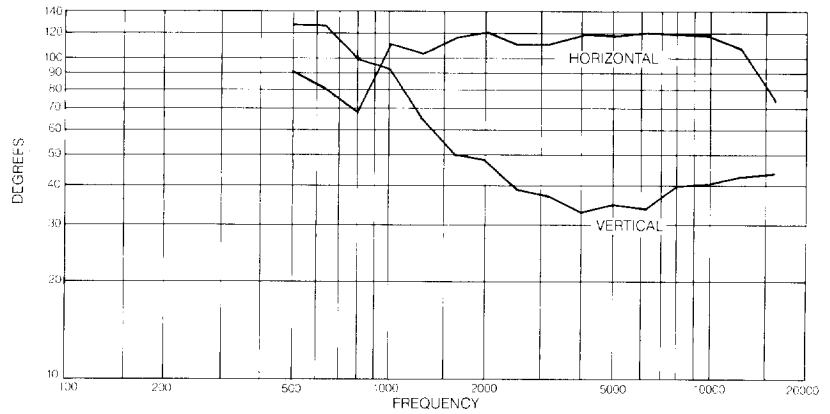

2. Off-Axis Horizontal and Vertical Frequency Response

On-axis response has been equalized in this graph to illustrate the uniformity of the on and off-axis response curves.

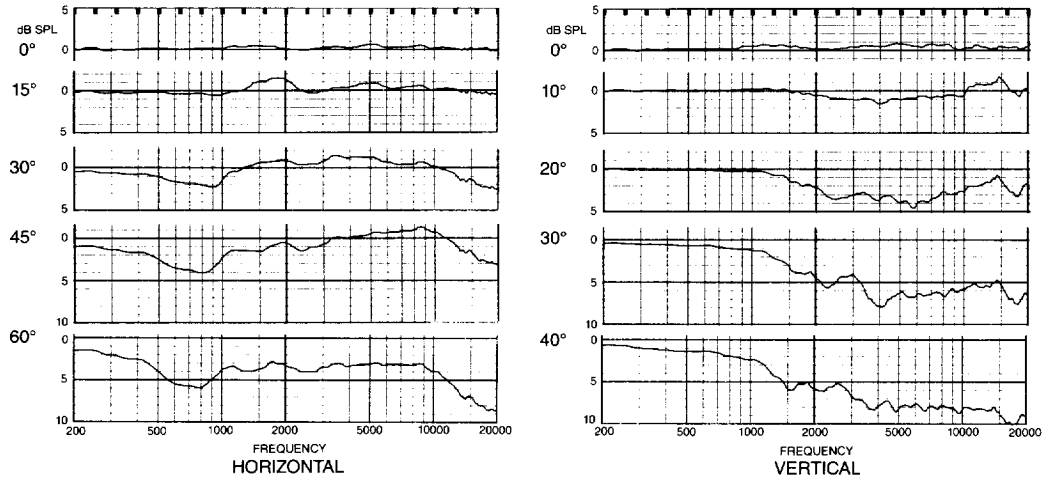

3. Unequalized Frequency Response (Measured with an Altec Lansing 288-8K Compression Driver)

The response curves exhibited here are very similar to the actual power response of the 288-8K driver measured on a plane wave tube because of the dispersion uniformity of the MR II 5124.

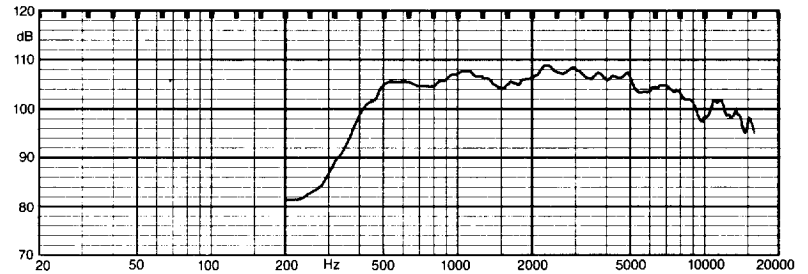

4. Q and DI vs Frequency (DI = 10 Log Q)

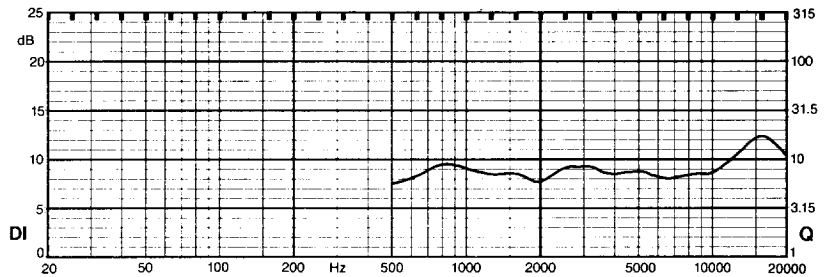

5. Solid-Angle Coverage

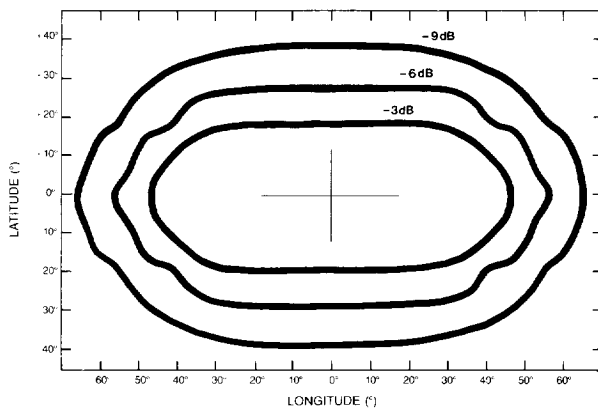

at 1 to 2 kHz

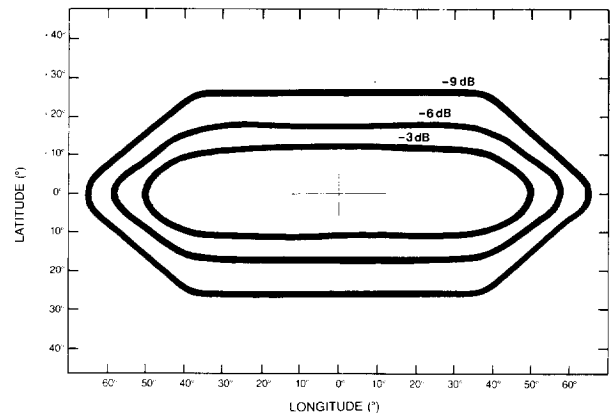

at 2 to 4 kHz (representative from 2 to 16kHz)

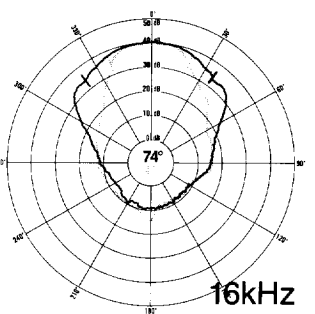
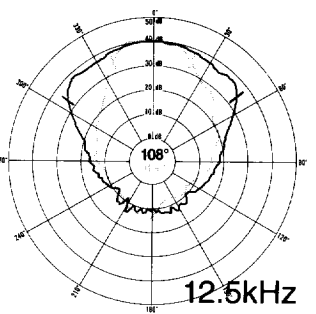
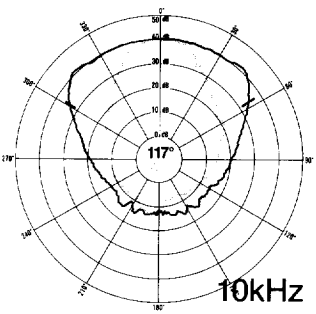
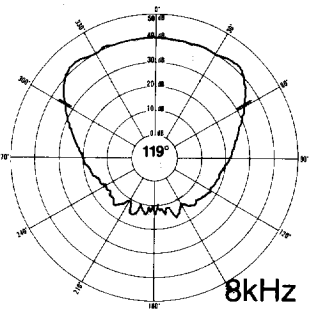
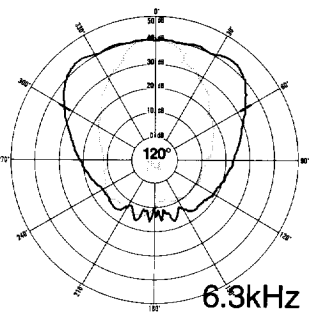
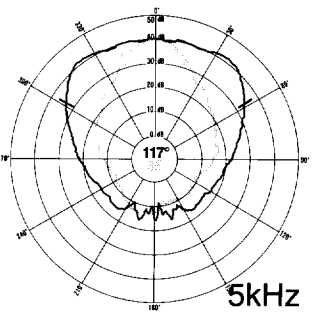
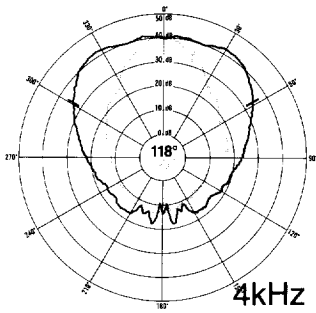
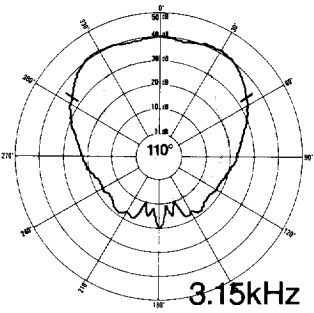
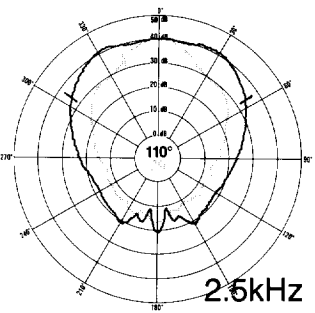
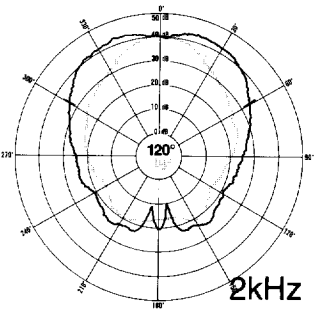
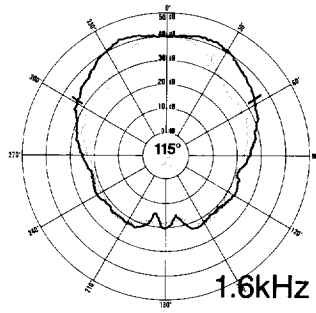
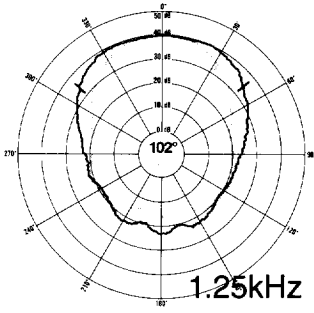
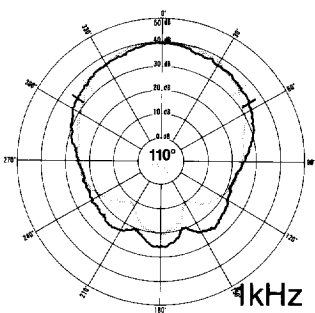
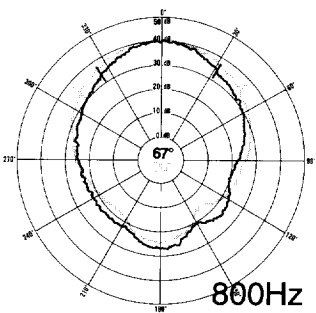
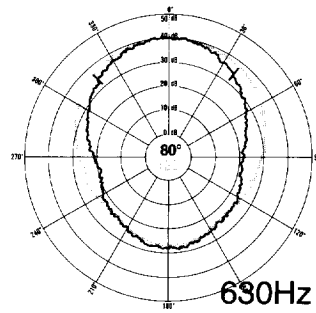
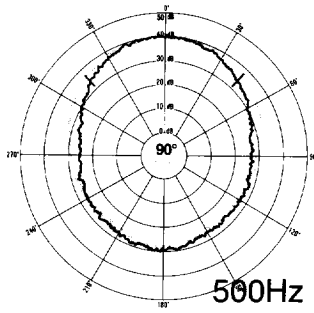

6. Polar Response Charts
 (using 1/3 octave
 bands of pink noise
 rotated about the
 apparent apex)

VERTICAL
 HORIZONTAL

ROW 1 (1 : 2)



ROW 2 (3 : 4)



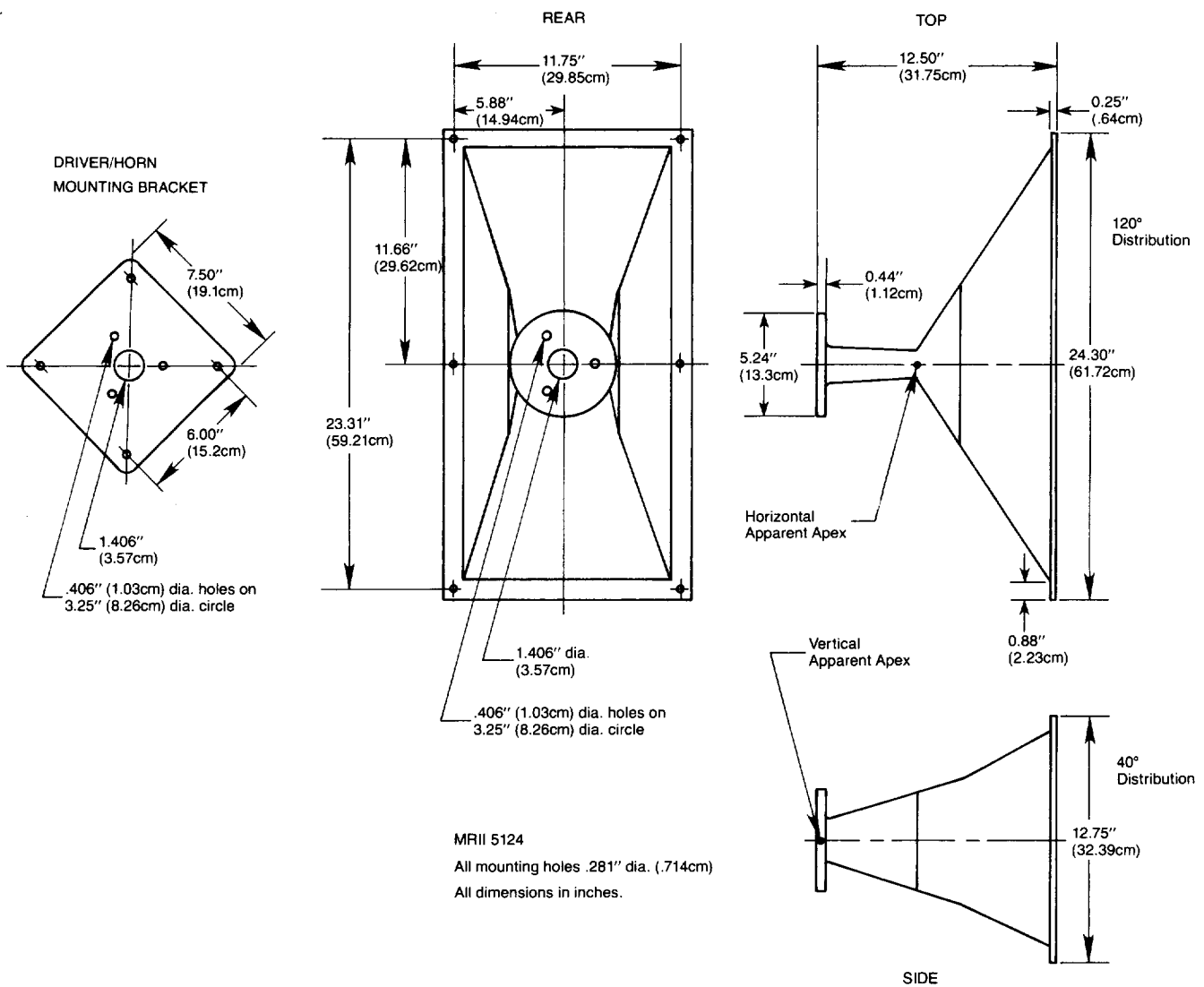

ARCHITECT'S AND ENGINEER'S SPECIFICATIONS

The loudspeaker shall be a directivity-control mid/high frequency horn. The horn shall meet the following performance criteria over the bandpass of 2 kHz to 16 kHz. Mean horizontal dispersion angle, 111° (+9°, -37°) with a standard deviation of 14°. Mean vertical dispersion angle, 39° (+9°, -6°) with a standard deviation of 5°.

Pressure sensitivity shall be 109 dB SPL at 1 meter on axis with one watt (E x I) input of band-limited pink noise from 500 Hz to 16 kHz applied to an attached model 288-type Altec Lansing compression driver.

The loudspeaker shall be the Altec Lansing Model MR II 5124.

**ALTEC
LANSING**

10500 WEST RENO AVENUE
P.O. BOX 26105, OKLAHOMA CITY, OKLAHOMA 73126-0105

ALTEC CORPORATION