

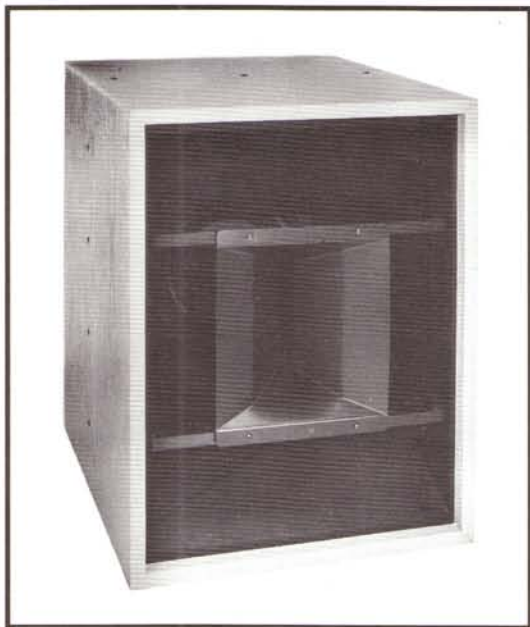

9294A 12" Duplex® Loudspeaker System



KEY FEATURES

- ★ High-Output Capability
- ★ Excellent Directivity Control
- ★ 550 Watts = 130 dB SPL
- ★ Enclosure Allows Refinishing
- ★ True Point Source

DESCRIPTION

The **9294A** is a two-way, factory assembled, sealed bass Duplex horn system. This compact system features the same high sensitivity, high output capability point source alignment as the **9864A** with excellent directivity control down to 150 Hz. The coverage at 500 Hz is 90° horizontal by 70° vertical and the systems nominal coverage is 90° horizontal by 40° vertical. The **9294A** utilizes the same technologies in the magnet structure (The Engine) as the 16.0 inch (40.6 cm) **9864A** which allows both the low and high frequency voice coil assemblies to be physically aligned creating a true point source device.

The **9294A** "Duplex" driver combines a 12.0 inch (30.5 cm) low frequency driver and a 1.4 inch (3.6 cm) high frequency compression driver coupled to a 90° x 40° constant directivity horn for smooth directivity through the crossover. The recommended crossover frequency is 1 kHz and a **9607A** plug-in

PRIMARY SPECIFICATIONS	
System Type:	Sealed bass horn type, two-way full-range loudspeaker system.
Pressure sensitivity:	(see note 1)
H.F.:	109 dB SPL (1 W, 1 kHz to 10 kHz, re: 20 μPa).
L.F.:	104 dB SPL (1 W, 125 Hz to 1 kHz, re: 20 μPa).
Frequency Response:	90 Hz to 15 kHz (see Figure 2, note 2).
Power Handling:	(see note 3)
H.F. (1 kHz to 10 kHz):	75 w, AES method. 150 w, continuous program. 300 w, peak power.
L.F. (50 Hz to 4 kHz):	200 w, AES method. 400 w, continuous program. 800 w, peak power.
Maximum Output:	(see note 4)
H.F.:	128 dB SPL, AES method. 131 dB SPL, continuous program. 134 dB SPL, peak power.
L.F.:	127 dB SPL, AES method. 130 dB SPL, continuous program. 133 dB SPL, peak power.

equalization module can be used to provide equalization in Altec Lansing electronic crossovers.

The enclosure will also accept the standard Altec Lansing passive crossover network. The enclosure is constructed from 3/4 inch (1.9 cm) thick, thoroughly braced 7-ply birch plywood lined with sound absorbent glass wool. Threaded insert mounting points are provided to conveniently attach the Altec Lansing **9200-SK** suspension kit. The system may be hung as a single unit or as part of a cluster. The enclosure is covered in a unique wood-grained vinyl which can be painted or stained to complement any interior. The enclosure is supplied with a removable black metal grille.

The **9294A** can be used individually or in arrays to create compact, high output and directivity controlled systems for use in churches, auditoriums, hotels and civic centers.

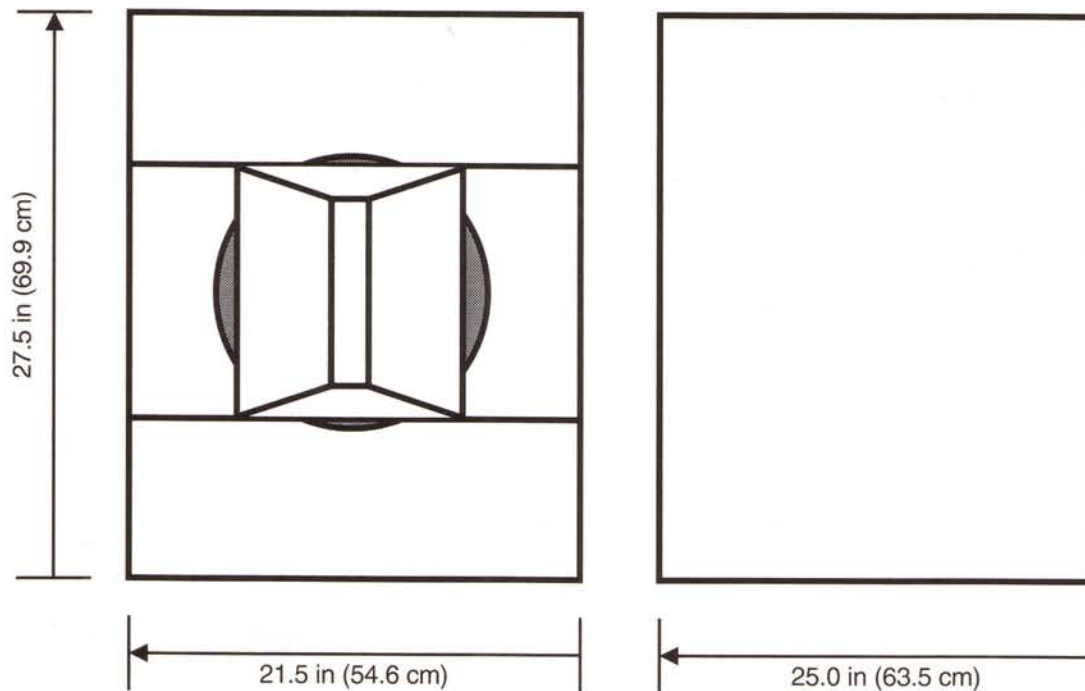

SPECIFICATIONS (continued)

Crossover Frequency:	1 kHz recommended.		wool. Includes mounting points for accessory 9200-SK suspension kit.
Impedance:			
H.F.:	8.0 ohms minimum.	Finish:	Architectural wood grain vinyl with black metal grille.
L.F.:	7.0 ohms minimum. 8.0 ohms nominal.	Dimensions:	
Components:	12.0 inch (30.5 cm), high efficiency, Duplex® loudspeaker.	Height:	27.5 inch (69.9 cm).
Input Terminals:	Large screw terminals.	Width:	21.5 inch (54.6 cm).
Replacement L.F.:	R9264A-LF.	Depth:	25.0 inch (63.5 cm).
Replacement H.F.:	25884.	Weight:	
Replacement Grille:	Model RG9264.	Net:	108.0 lbs (49.0 kgs).
Enclosure:	Sealed bass horn type, built of ¾ inch (1.9 cm) birch plywood with appropriate bracing, lined with glass	Shipping:	120.0 lbs (54.4 kgs).
		Accessories:	Altec Lansing 9200-SK suspension kit.

Altec Lansing continually strives to improve products and performance. Therefore, specifications are subject to change without notice.

NOTES ON MEASUREMENT CONDITIONS

1. Pink noise signal, one Watt calculated using E^2/Z_{min} , 3.16 meter-measurement distance referred to one meter.
2. On-axis, one Watt calculated using E^2/Z_{min} , 3.16 meter-measurement distance referred to one meter, low frequencies corrected for anechoic chamber error.
3. This system rating patterned after the AES method for individual driver, where the test signal is pink noise with a 6 dB crest factor over the bandwidth of the system, with power calculated using the E^2/Z_{min} , for two hours.
4. This measurement made under the same conditions as Pressure Sensitivity, but at rated power, and takes into account any power compression effects due to non-linearities in the system.
5. Distortion components invalid above 10 kHz. The distortion at any given frequency may be found by graphically taking the difference between the fundamental and harmonic, and adding the number of Decibels which the harmonic has been raised on the graph and apply the formula:

$$\% \text{ distortion} = 100 \times 10^{(\text{difference in dB}/20)}$$

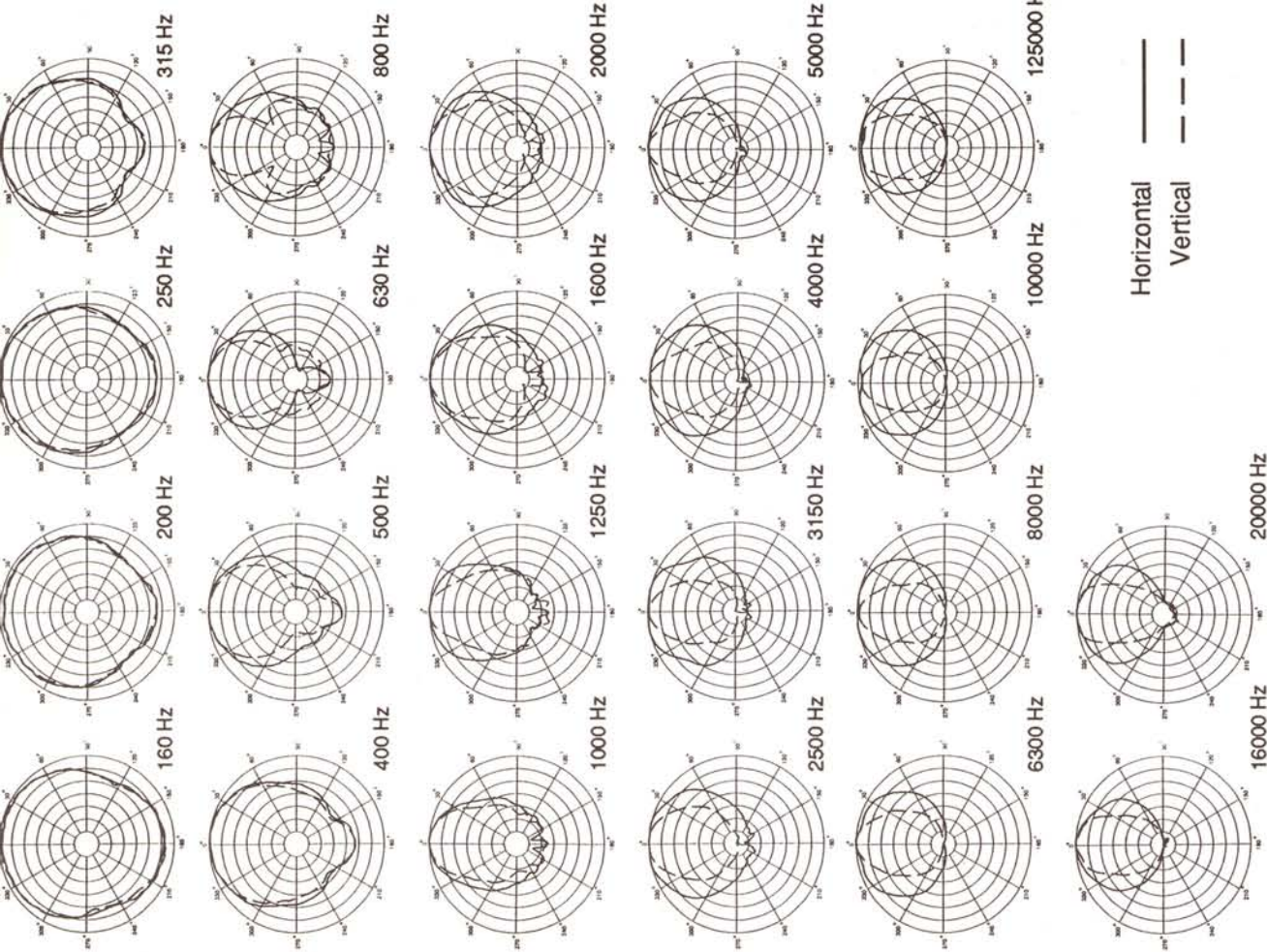

Figure 1: 1/3-Octave Polar Response

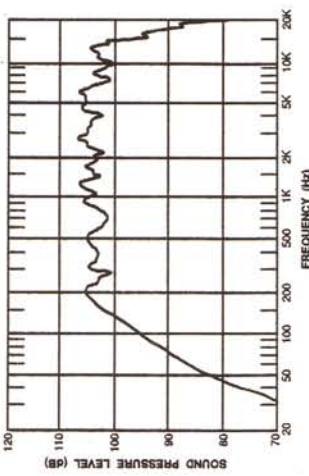

Figure 2: Frequency Response

Figure 3: Dispersion Angle

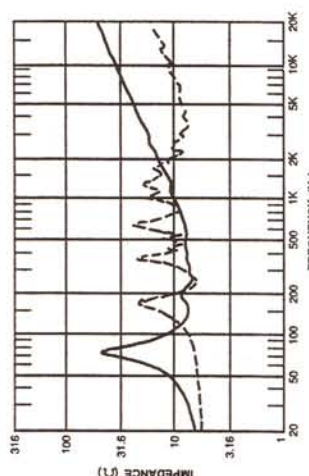
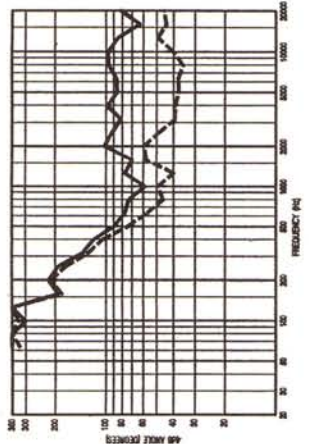

Figure 4: Magnitude of Impedance

Figure 5: Q and Directivity Index

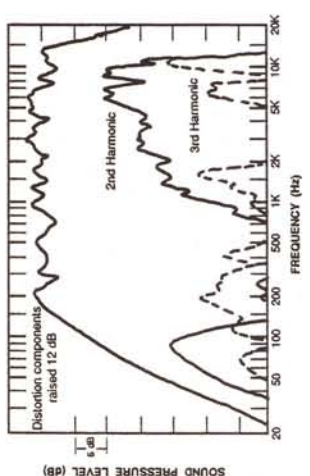
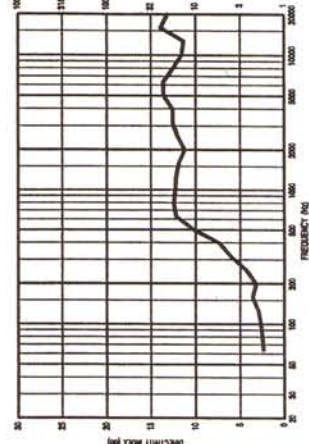

Figure 6: Harmonic Distortion at 0.01 Rated Power

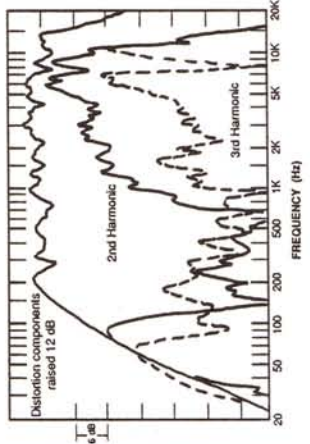
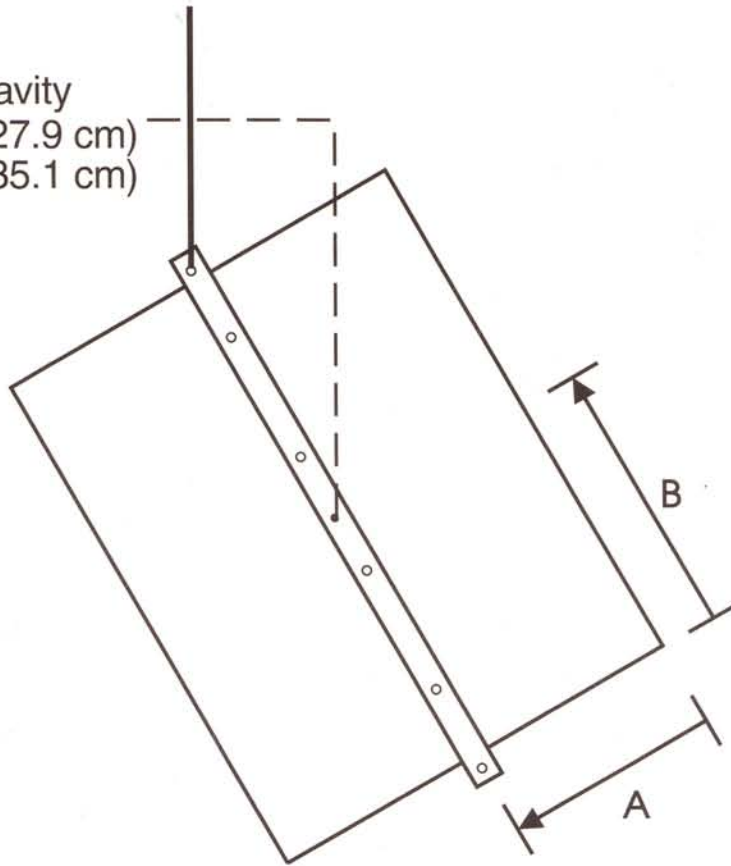

Figure 7: Harmonic Distortion at 0.1 Rated Power

9294A
Center of Gravity
A: 11.0 inches (27.9 cm)
B: 13.8 inches (35.1 cm)



ARCHITECT'S AND ENGINEER'S SPECIFICATIONS

The loudspeaker system shall be of the vented bass horn type consisting of one 12.0 inch (30.5 cm) high power Duplex® loudspeaker with a coaxially embedded 1.4 inch (3.6 cm) compression driver loaded with a 90° by 40° constant directivity horn. The loudspeaker system shall meet the following performance criteria: Power handling, LF - 200 watts (90 Hz to 1 kHz), HF - 75 watts (1 kHz to 15 kHz) band limited pink noise with 6 dB crest factor. Frequency response, smooth and uniformly usable from 90 Hz to 15 kHz. Pressure sensitivity, 109 dB SPL from 1 kHz to 10 kHz, and 104 dB SPL from 125 Hz to 1 kHz,

one watt at one meter on axis. The enclosure shall be constructed of 3/4 inch 7-ply birch plywood and shall be heavily braced and lined with sound absorbent glass wool. The finish of the enclosure shall be an architectural wood grain vinyl that is paintable or stainable with a black metal grille. The dimensions of the enclosure shall be 27.5 inches (69.9 cm) high by 21.5 inches (54.6 cm) wide by 25.0 inches (63.5 cm) deep. The loudspeaker system shall weigh 108.0 lbs (49.0 kgs).

The loudspeaker system shall be the Altec Lansing 9294A.



a MARK IV company

P.O. BOX 26105 • OKLAHOMA CITY, OK 73126-0105 • U.S.A.

Phone: 405/324-5311 or FAX: 405/324-8981

© 1994 ALTEC LANSING CORPORATION